

PLAN OF SUBDIVISION

EDITION 2

PS 600696N

LOCATION OF LAND

PARISH: CUT PAW PAW

TOWNSHIP: -----

SECTION: 3

CROWN ALLOTMENT: 5

CROWN PORTION: -----

TITLE REFERENCE: VOL.9703 FOL.678
VOL.10539 FOL.010

LAST PLAN REFERENCE: CP161031R, LOT 1 PS434347P

POSTAL ADDRESS: 1 MORELAND STREET,
(at time of subdivision) FOOTSCRAY, VIC. 3011

MGA CO-ORDINATES: E: 315,835 ZONE: 55
(of approx centre of land in plan) N: 5,814,170 GDA 94

Council Name: Maribyrnong City Council

NOTATIONS

BUILDING 'A' IS THE BUILDING ON THE LAND IN THE PLAN CONTAINING LOTS 1 TO 45, (ALL INCLUSIVE) AND COMMON PROPERTY 1 AND 2.

COMMON PROPERTY 2 IS ALL THE LAND IN THE PART OF THE PLAN DEFINED AS BUILDING 'A' EXCEPT LOTS 1 TO 45 AND COMMON PROPERTY 1 AND INCLUDES THE STRUCTURE OF ALL WALLS, FLOORS AND CEILINGS WHICH DEFINE BOUNDARIES IN LOTS 1 TO 45 AND COMMON PROPERTY 1.

ALL INTERNAL DUCTS, PIPES, SHAFTS, CABLE DUCTS, VENTS, STRUCTURAL WALLS DEFINING BOUNDARIES AND FLOOR SLABS WITHIN THE LAND DESCRIBED AS BUILDING 'A' ARE DEEMED TO BE PART OF COMMON PROPERTY 2. THE POSITIONS OF THESE INTERNAL DUCTS, PIPES, SHAFTS, CABLE DUCTS, VENTS, STRUCTURAL WALLS DEFINING BOUNDARIES AND FLOOR SLABS MAY NOT HAVE BEEN SHOWN ON THE DIAGRAMS CONTAINED HEREIN.

SUBDIVISION (PROCEDURES) REGS 2000 APPLY TO THE LAND DESCRIBED AS BUILDING 'A'

VESTING OF ROADS AND/OR RESERVES

| IDENTIFIER | COUNCIL/BODY/PERSON |
|------------|---------------------|
| NIL | NIL |

BUILDING 'B' IS THE BUILDING ON THE LAND IN THE PLAN CONTAINING LOTS 61 TO 64, 81, 101 TO 122, 201 TO 225, 301 TO 325, 401 TO 425, 501 TO 525, 601 TO 625, 701 TO 725, 801 TO 821, 901 TO 916, 1001 TO 1014 (ALL INCLUSIVE) AND COMMON PROPERTY 3 AND 4.

COMMON PROPERTY 3 IS ALL THE LAND IN THE PART OF THE PLAN DEFINED AS BUILDING 'B' EXCEPT LOTS 61 TO 64, 81, 101 TO 122, 201 TO 225, 301 TO 325, 401 TO 425, 501 TO 525, 601 TO 625, 701 TO 725, 801 TO 821, 901 TO 916, 1001 TO 1014 AND COMMON PROPERTY 4 AND INCLUDES THE STRUCTURE OF ALL WALLS, FLOORS, CEILINGS, WINDOWS, DOORS AND BALUSTRADES WHICH DEFINE BOUNDARIES.

ALL INTERNAL COLUMNS, SERVICE DUCTS, PIPE SHAFTS AND CABLE DUCTS AND SERVICE INSTALLATIONS WITHIN BUILDING 'B' ARE DEEMED TO BE PART OF COMMON PROPERTY 3. THE POSITIONS OF THESE COLUMNS, SERVICE DUCTS, PIPE SHAFTS AND CABLE DUCTS AND SERVICE INSTALLATIONS MAY NOT HAVE BEEN SHOWN ON THE DIAGRAMS CONTAINED HEREIN.

SUBDIVISION (REGISTRAR'S REQUIREMENTS) REGS 2011 APPLY TO THE LAND DESCRIBED AS BUILDING 'B'

NOTATIONS

DEPTH LIMITATION: Does Not Apply

SURVEY: This plan is based on survey.

STAGING: This is a staged subdivision.

PLANNING PERMIT No: TP 279 / 2016

Boundaries shown by thick continuous lines are defined by buildings.

Location of boundaries defined by buildings -

Exterior Face: Boundaries marked "E".

Interior Face: All other boundaries

LOTS ON THIS PLAN MAY BE AFFECTED BY ONE OR MORE OWNER'S CORPORATIONS.

FOR DETAILS OF ANY OWNERS CORPORATIONS INCLUDING PURPOSE, RESPONSIBILITY, ENTITLEMENT & LIABILITY SEE OWNERS CORPORATION SEARCH REPORT, OWNERS CORPORATION ADDITIONAL INFORMATION AND IF APPLICABLE, OWNERS CORPORATION RULES.

This survey has been connected to permanent marks No(s).
In Proclaimed Survey Area No.

B DENOTES BALCONY, CP DENOTES COMMON PROPERTY.

EASEMENT INFORMATION

LEGEND: A - Appurtenant Easement E - Encumbering Easement R - Encumbering Easement (Road)

Easements and Rights pursuant to Section 12 (2) of the Subdivision Act 1988 set aside in Stage 1 applies to all the land on this plan.

| Easement Reference | Purpose | Width (Metres) | Origin | Land Benefited/In Favour Of |
|--------------------|---|----------------|------------|---|
| E-1 | CARRIAGEWAY (LIMITED IN HEIGHT & DEPTH SEE SECTION N-N') | SEE PLAN | PS 600696N | LOTS ON PS 600696N |
| E-2 | PEDESTRIAN WAY (LIMITED IN DEPTH SEE SECTION D-D') | 1.20 | PS 600696N | LOTS ON PS 600696N |
| E-3 | ELECTRICITY SUPPLY (SUB-STATION) | SEE PLAN | THIS PLAN | JEMENA ELECTRICITY NETWORKS (VIC) LTD. (ACN 064 651 083) |
| E-4 | ACCESS WAY FOR MAINTENANCE OF SERVICES (LIMITED IN HEIGHT & DEPTH SEE SECTION C-C') | SEE PLAN | THIS PLAN | LOTS ON THIS STAGE PLAN THAT ARE DEFINED AS BEING PART OF BUILDING 'B' (SEE NOTATIONS ABOVE). |

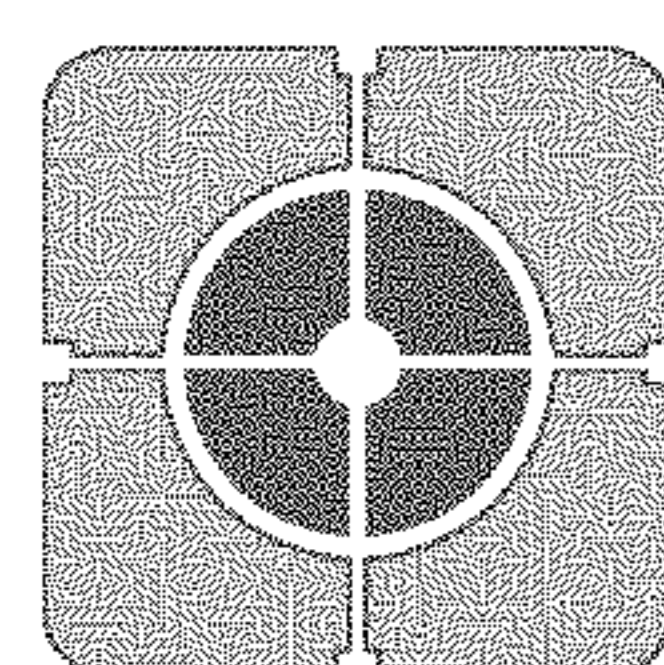

Peninsula Survey Group PTY LTD
Consulting Land Surveyors
24A Progress Street, Mornington, VIC. 3931.
Phone: 9787 2980 mail@peninsulasurvey.com.au
ACN 067 077 614

FILE REF: 6241 / PS

Digitally signed by: Alan Leslie Runting (Peninsula Survey Group Pty Ltd),
Surveyor's Plan Version (4.1),
15/11/2016

ORIGINAL SHEET
SIZE: A3

SHEET 1 OF

THIS IS A LAND VICTORIA COMPILED PLAN
FOR DETAILS SEE MODIFICATION TABLE HEREIN

PLAN OF SUBDIVISION

Plan Number
PS600696N

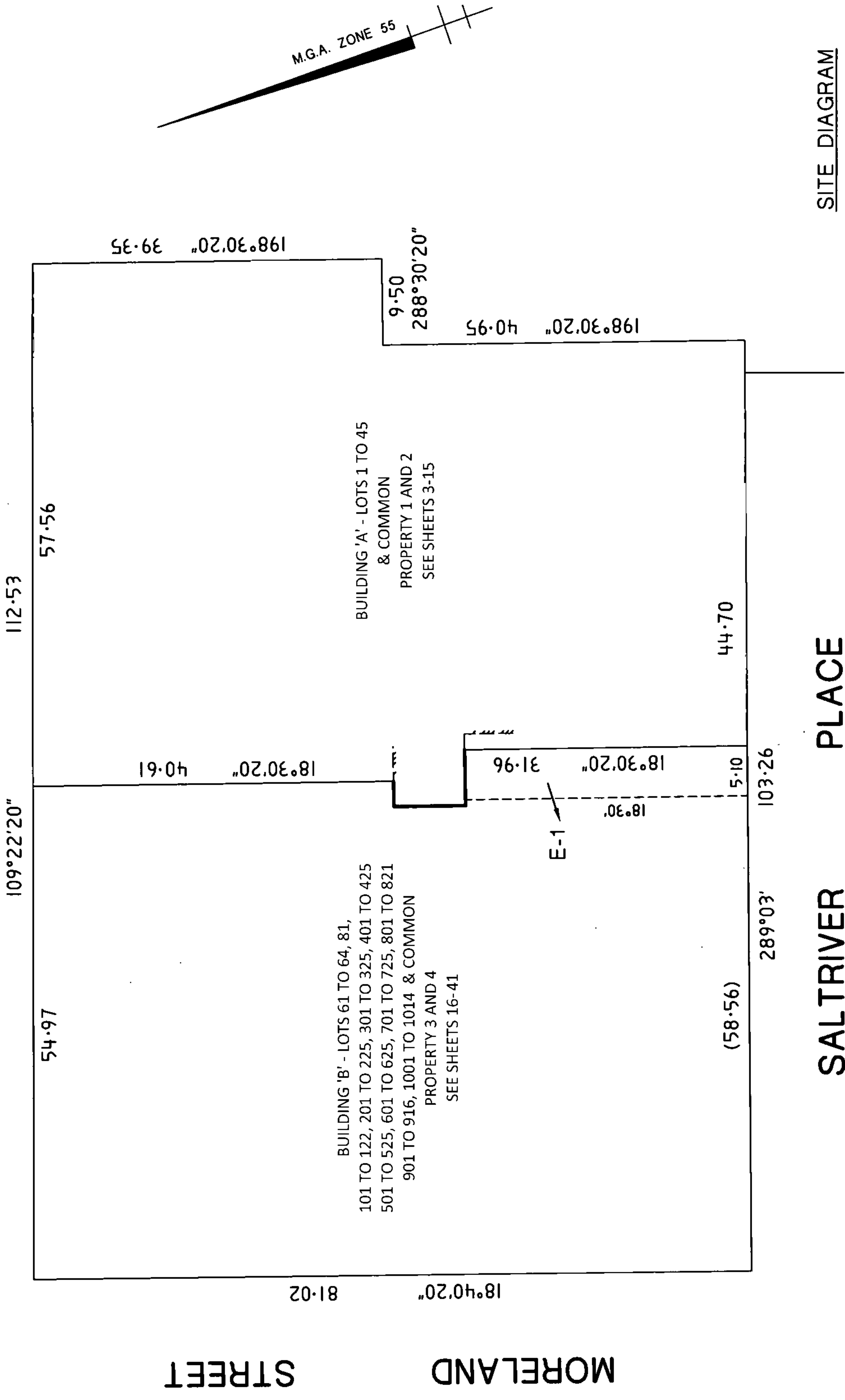

Sheet 2

.....*Neil Oliver*.....
Date 25/06/09
Council Delegate Signature
Original sheet size A3

LICENSED SURVEYOR : NEIL OLIVER
Signature*Neil Oliver*..... Date 19/6/09
REF. 9718-S1 VERSION 13 17/06/09 MEV

SCALE 1:500 ORIGINAL SHEET SIZE A3

SCALE 0 10 20
LENGTHS ARE IN METRES

TAYLORS DEVELOPMENT STRATEGISTS
BSI 180001
 PTY. LTD. A.B.N. 48 042 392 373
 Land Surveying · Town Planning · Development Strategy · Project Coordination · Urban Design · G.I.S.
 BUILDING 6, 270 FERNTREE GULLY ROAD, NOTTING HILL 3168 Tel: 9501 2800 Fax: 9501 2844
 Email: us@taylorsts.com.au Web Site: www.taylorsts.com.au

PLAN OF SUBDIVISION

Plan Number
PS600696N

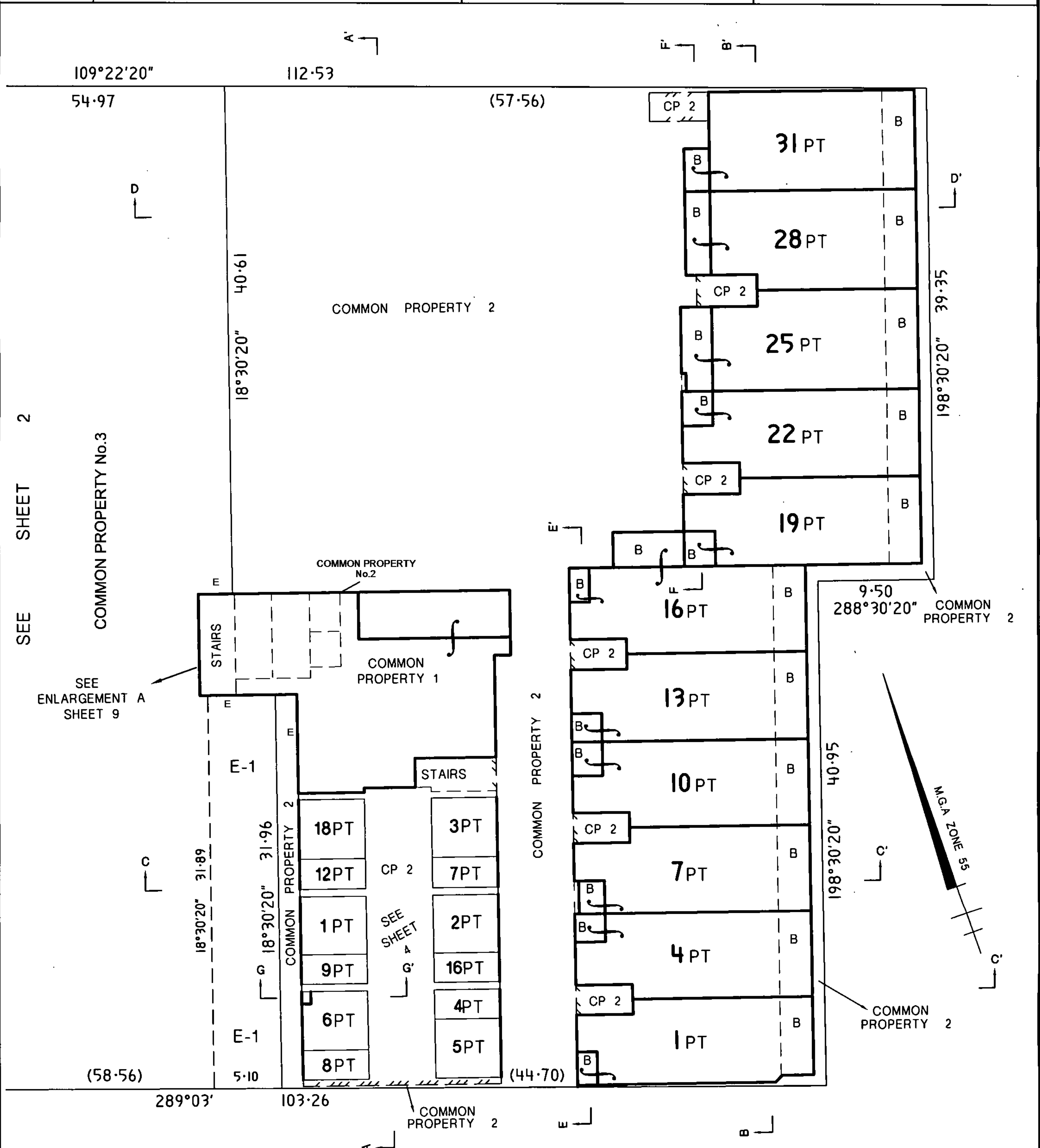

SALTRIVER PLACE

LEVEL 1
DIAGRAM 1

TAYLORS DEVELOPMENT STRATEGISTS
BSI ISO9001 Certificate No. 851
 PTY. LTD. A.B.N. 48 042 392 373
 Land Surveying · Town Planning · Development Strategy · Project Co-ordination · Urban Design · G.I.S.
 BUILDING 8, 270 FERNTREE GULLY ROAD, NOTTING HILL 3168 Tel.9501 2800 Fax.9501 2844
 Email: tds@taylorsds.com.au Web Site: www.taylorsds.com.au

Sheet 3

| | | | | |
|----------|------------|---------------------|--|---|
| ORIGINAL | SCALE | LICENSED SURVEYOR : | NEIL OLIVER | Date <u>19/6/09</u> Council Delegate Signature Original sheet size A3 |
| SCALE | SHEET SIZE | Signature | Date <u>19/6/09</u> VERSION 13 17/06/09 MFV | |
| 1:300 | A3 | REF. 9718-S1 | | |

PLAN OF SUBDIVISION

Plan Number
PS600696N

SEE SHEET 3

COMMON PROPERTY 1

STAIRS

MCC194 ZONE 55

COMMON PROPERTY No.3

18°30'20"

E-1

18°30'20"

G

0.58 COMMON PROPERTY 2

COMMON PROPERTY 2

G

COMMON PROPERTY 2

E-1

5.10

289°03'

108°30'

COMMON PROPERTY 2

0.56



TAYLORS DEVELOPMENT STRATEGISTS
ISO9001 Certificate No 851
 PTY. LTD. A.B.N. 48 042 392 373
 Land Surveying · Town Planning · Development Strategy · Project Co-ordination · Urban Design · G.I.S.
 BUILDING 8, 270 FERNTREE GULLY ROAD, NOTTING HILL 3168 Tel.9501 2800 Fax.9501 2844
 Email: tds@taylorsds.com.au Web Site: www.taylorsds.com.au

LEVEL 1

Sheet 4

ORIGINAL

SCALE

LICENSED SURVEYOR :

NEIL OLIVER

SCALE SHEET SIZE

1.25 0 2.5 5

Signature  Date 19/6/09

Date 25/06/09

1:125 A3

LENGTHS ARE IN METRES

REF. 9718-S1

VERSION 13 17/06/09 MFV

Council Delegate Signature

Original sheet size A3

PLAN OF SUBDIVISION

Plan Number
PS600696N

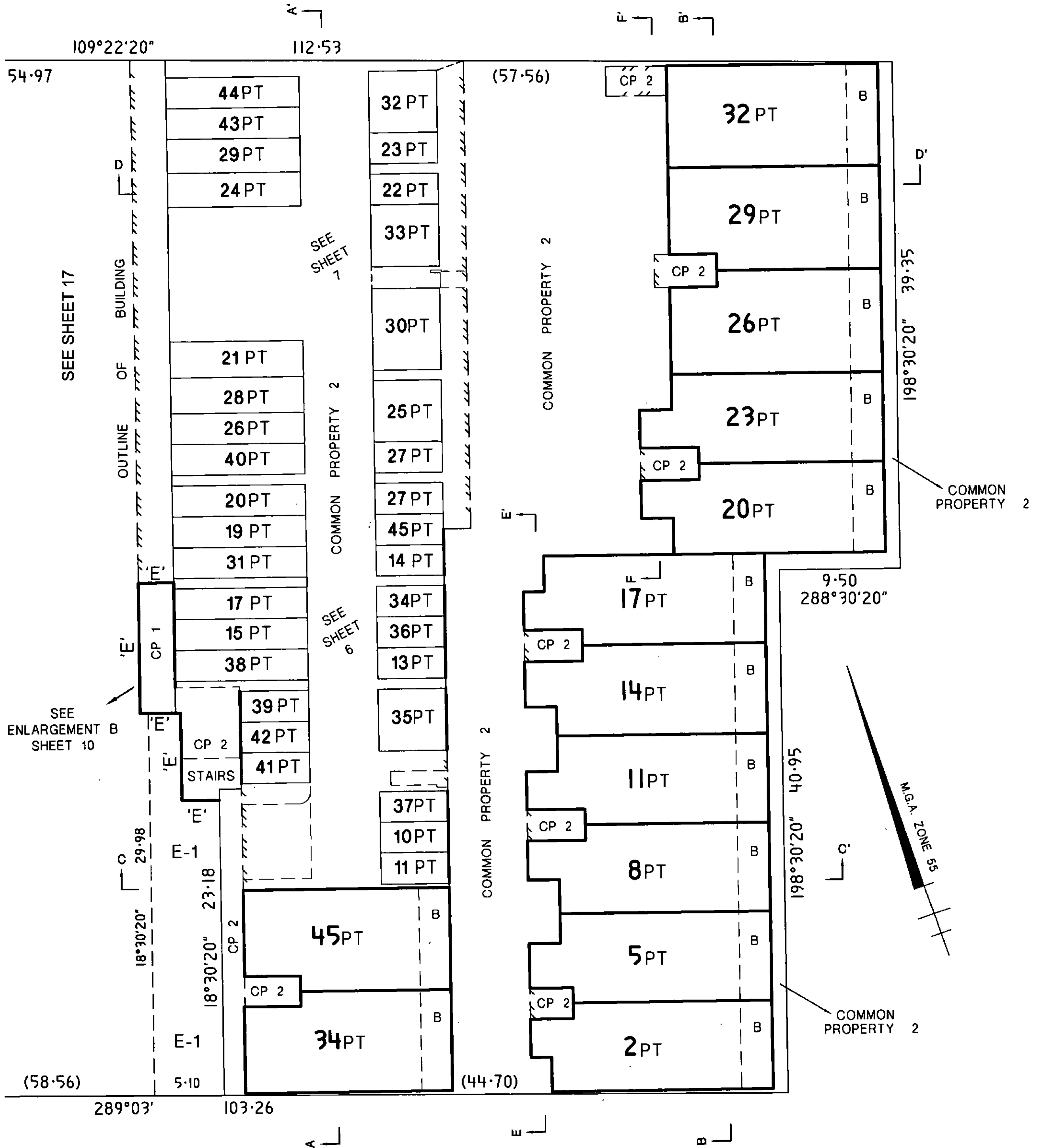

TAYLORS 
 DEVELOPMENT STRATEGISTS
 PTY. LTD. A.B.N. 48 042 392 373
 Land Surveying · Town Planning · Development Strategy · Project Co-ordination · Urban Design · G.I.S.
 BUILDING 8, 270 FERN TREE GULLY ROAD, NOTTING HILL 3168 Tel.9501 2900 Fax.9501 2844
 Email: tds@taylorsds.com.au Web Site: www.taylorsds.com.au

LEVEL 2
DIAGRAM 2

Sheet 5

| | |
|----------|------------|
| ORIGINAL | SCALE |
| SCALE | SHEET SIZE |
| 1:300 | A3 |

3 0 6 12
LENGTHS ARE IN METRES

LICENSED SURVEYOR : NEIL OLIVER
 Signature  Date 19/6/09
 REF. 9718-S1 VERSION 13 17/06/09 MFV

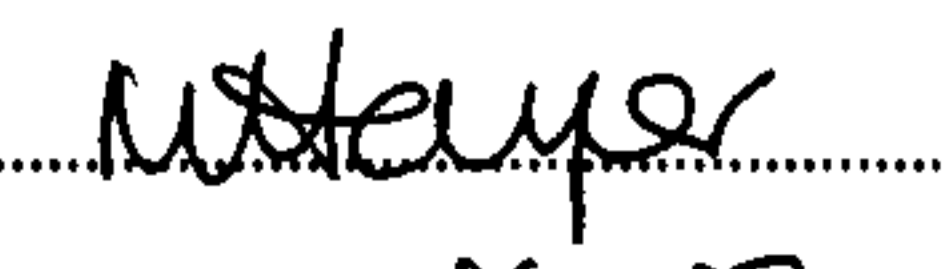
 Date 25/06/09
 Council Delegate Signature
 Original sheet size A3

PLAN OF SUBDIVISION

Plan Number
PS600696N

SEE SHEET 7

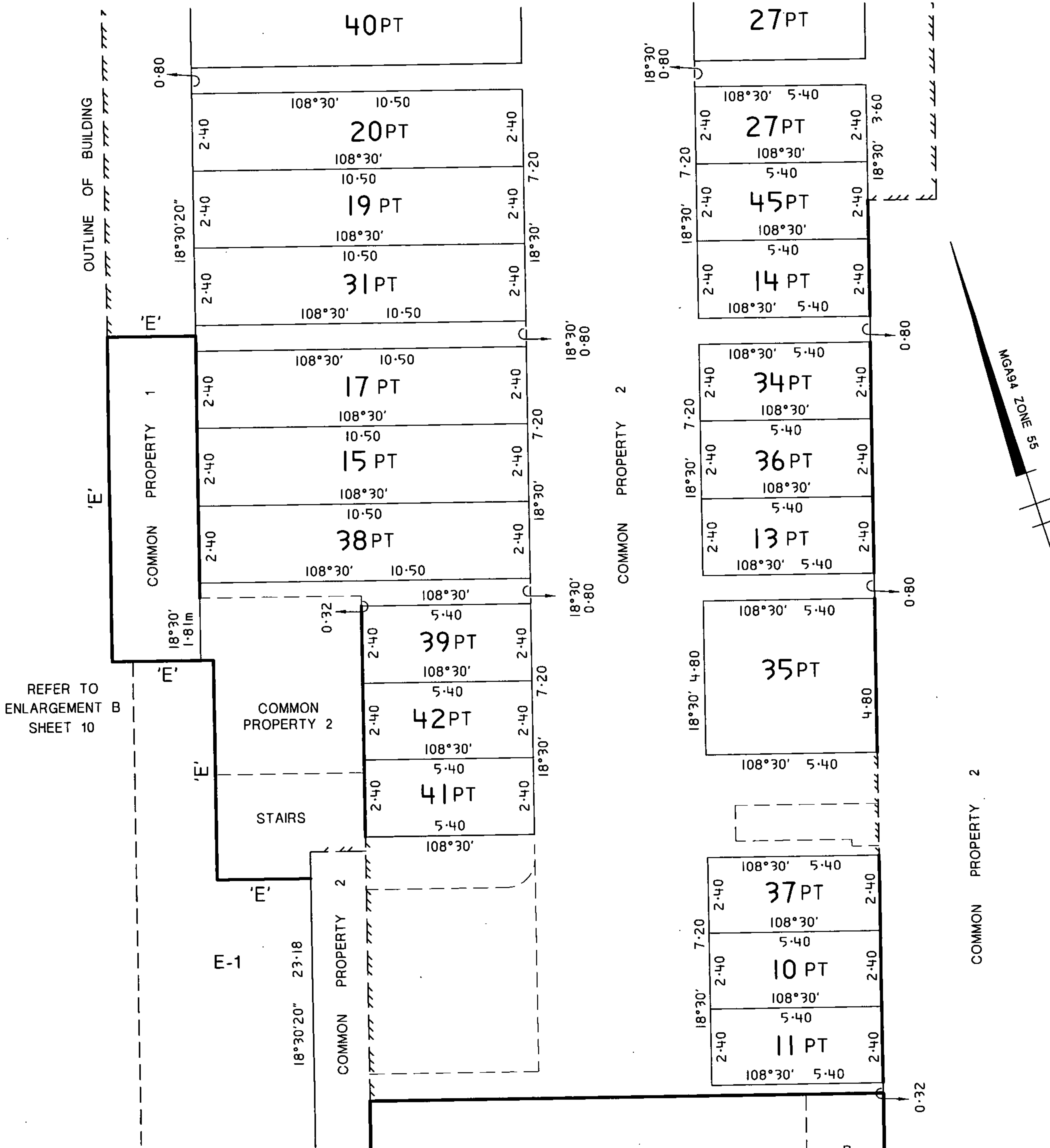

TAYLORS DEVELOPMENT STRATEGISTS
BSI ISO9001 Certificate No 851
 Land Surveying · Town Planning · Development Strategy · Project Co-ordination · Urban Design · G.I.S.
 BUILDING 8, 270 FERN TREE GULLY ROAD, NOTTING HILL 3168 Tel.9501 2800 Fax.9501 2844
 Email: tds@taylorsds.com.au Web Site: www.taylorsds.com.au

45 PT

LEVEL 2

| | | | | | | | |
|----------|------------|-----------------------|--|---------------------|--------------------|----------------------------|----------|
| ORIGINAL | | SCALE | | LICENSED SURVEYOR : | NEIL OLIVER | Sheet 6 | |
| SCALE | SHEET SIZE | 1.25 0 2.5 5 | | Signature | <i>Neil Oliver</i> | Date | 19/6/09 |
| 1:125 | A3 | LENGTHS ARE IN METRES | | REF. 9718-S1 | VERSION 13 | Date | 25/06/09 |
| | | | | | | Council Delegate Signature | |
| | | | | | | Original sheet size A3 | |

PLAN OF SUBDIVISION

Plan Number
PS600696N

109°22'20"

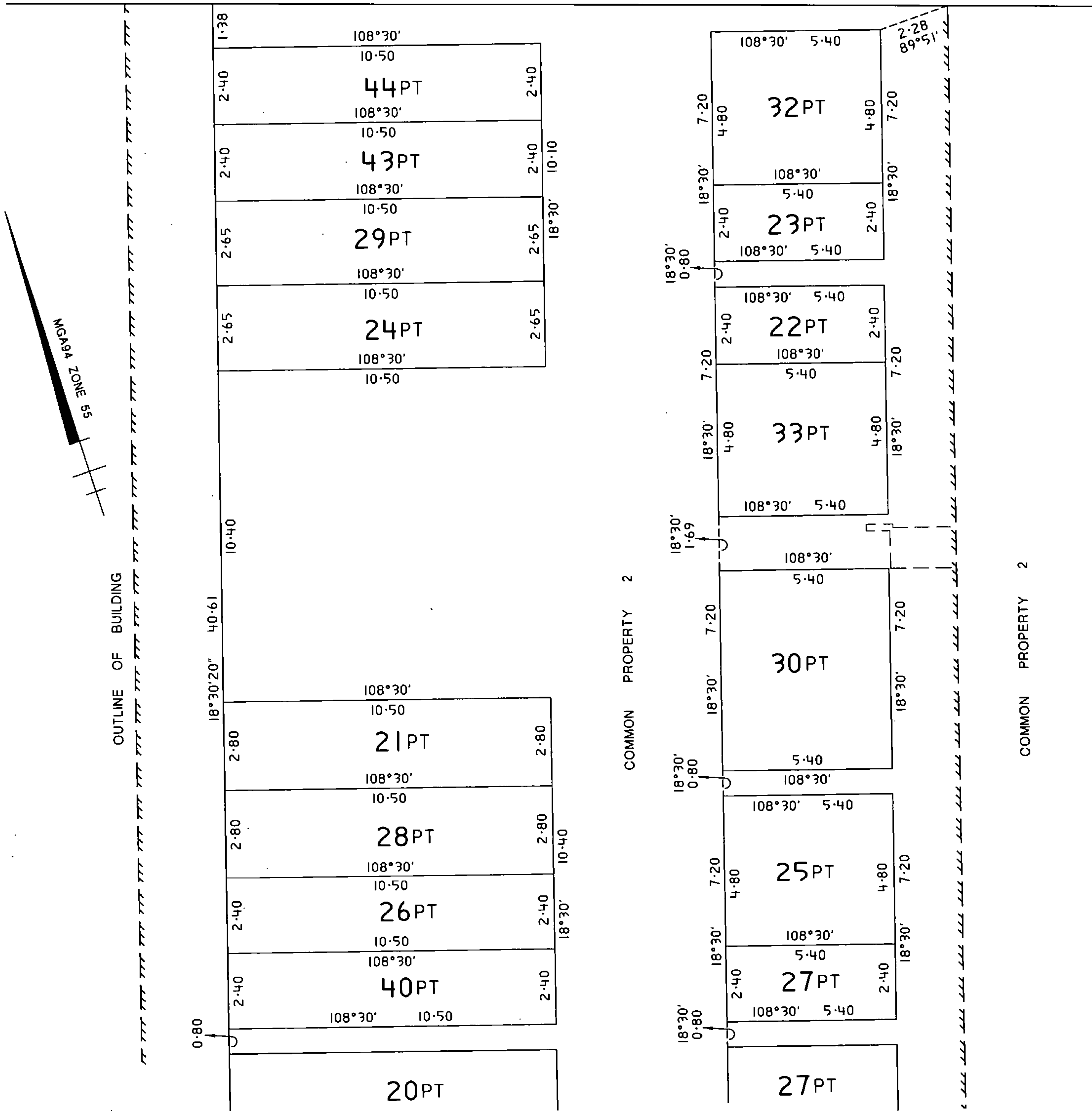

SEE SHEET 6

TAYLORS 
 DEVELOPMENT STRATEGISTS
 PTY. LTD. A.B.N. 48 042 392 373
 ISO9001 Certificate No 851
 Land Surveying · Town Planning · Development Strategy · Project Co-ordination · Urban Design · G.I.S.
 BUILDING 8, 270 FERNTREE GULLY ROAD, NOTTING HILL 3168 Tel.9501 2800 Fax.9501 2844
 Email: tds@taylorsds.com.au Web Site: www.taylorsds.com.au

LEVEL 2

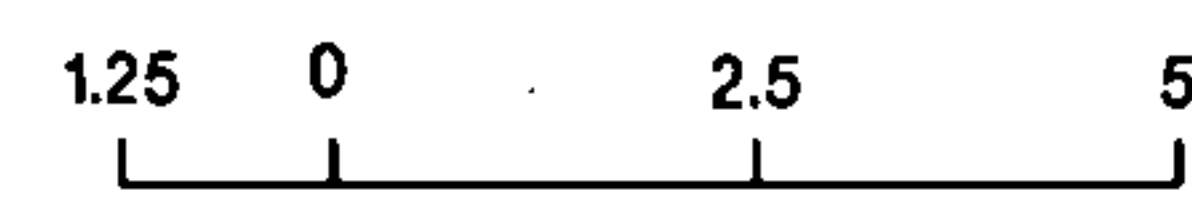
| | |
|--|------------|
| ORIGINAL | SCALE |
| SCALE | SHEET SIZE |
| 1:125 | A3 |
|  <p>LENGTHS ARE IN METRES</p> | |

LICENSED SURVEYOR : NEIL OLIVER

Signature  Date 19/6/09

REF. 9718-S1 VERSION 13 17/06/09 MFV

Sheet 7



Date 25/06/09

Council Delegate Signature

Original sheet size A3

PLAN OF SUBDIVISION

Plan Number
PS600696N

SEE ENLARGEMENT C SHEET 11
109°22'20" 112.53

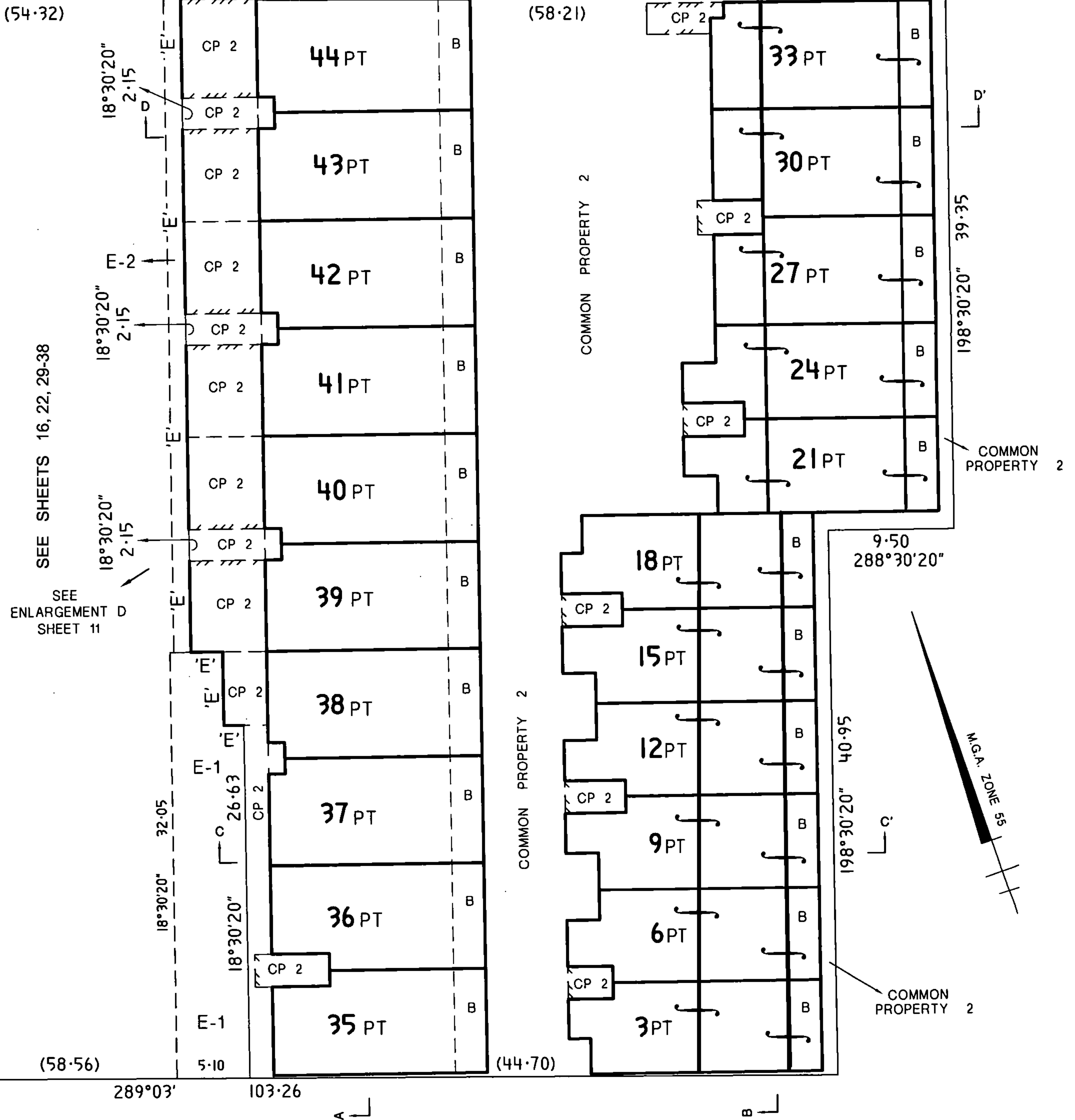

LEVEL 3
DIAGRAM 3

TAYLORS 
DEVELOPMENT STRATEGISTS
PTY. LTD. A.B.N. 48 042 392 373
ISO9001 Certificate No 851
• Land Surveying • Town Planning • Development Strategy • Project Co-ordination • Urban Design • G.I.S.
BUILDING B, 270 FERN TREE GULLY ROAD, NOTTING HILL 3168 Tel.9501 2800 Fax.9501 2844
Email: tds@taylorsds.com.au Web Site: www.taylorsds.com.au

Sheet 8

ORIGINAL
SCALE SHEET SIZE
1:300 A3

SCALE
3 0 6 12
LENGTHS ARE IN METRES

LICENSED SURVEYOR : NEIL OLIVER

Signature  Date 19/6/09

REF. 9718-S1

VERSION 13 17/06/09 MFV



Date 25/06/09
Council Delegate Signature
Original sheet size A3

PLAN OF SUBDIVISION

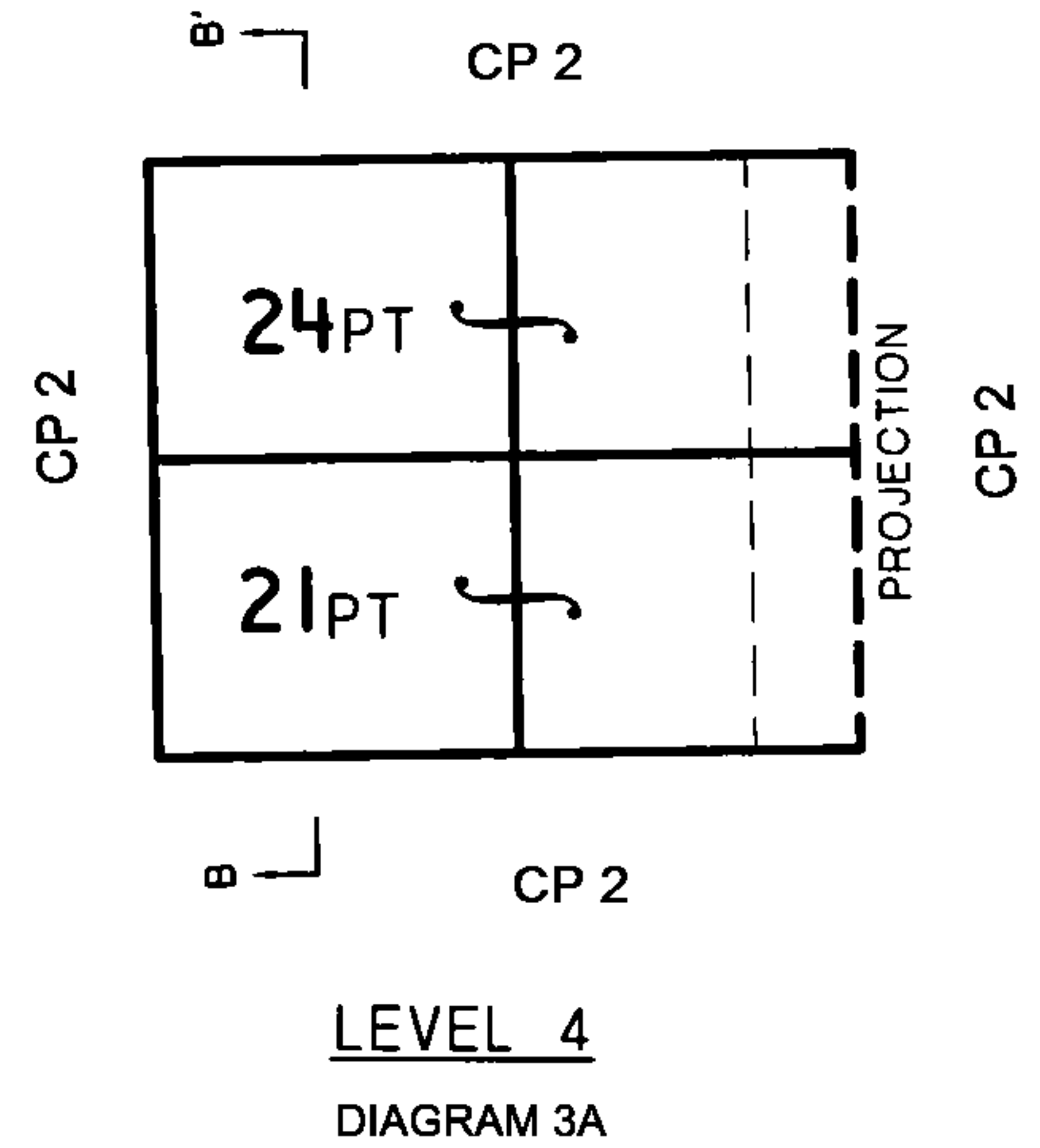
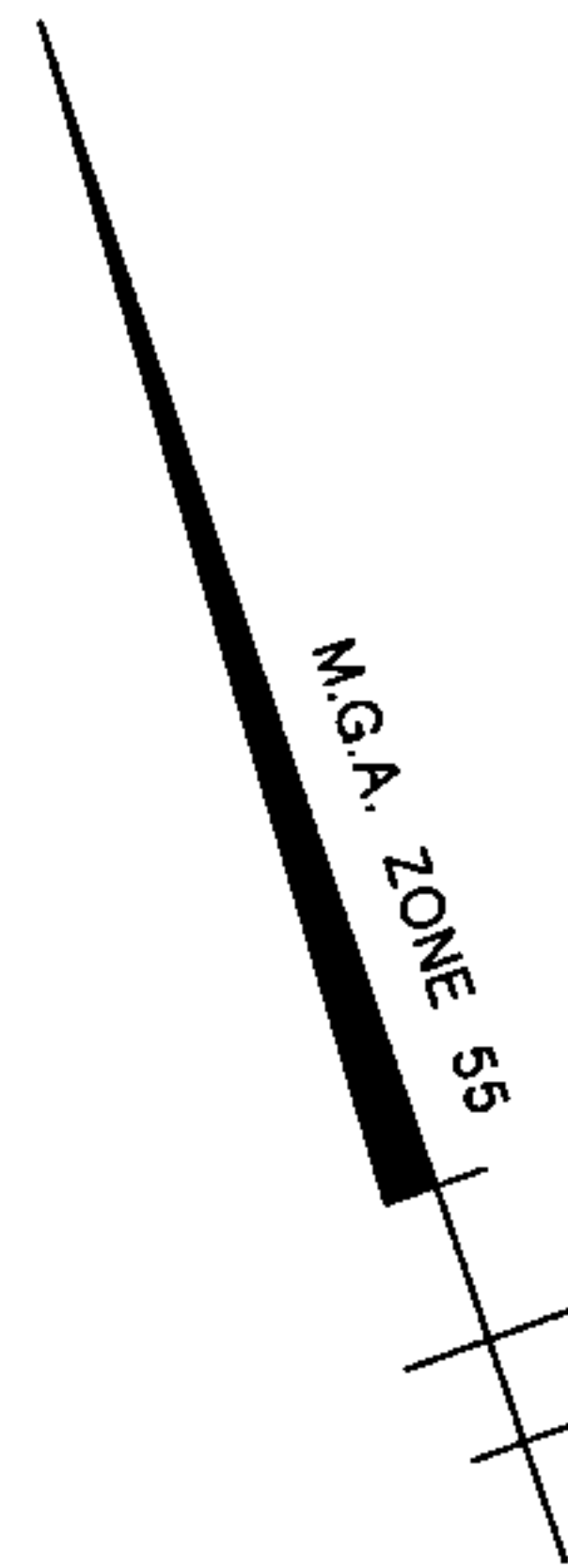
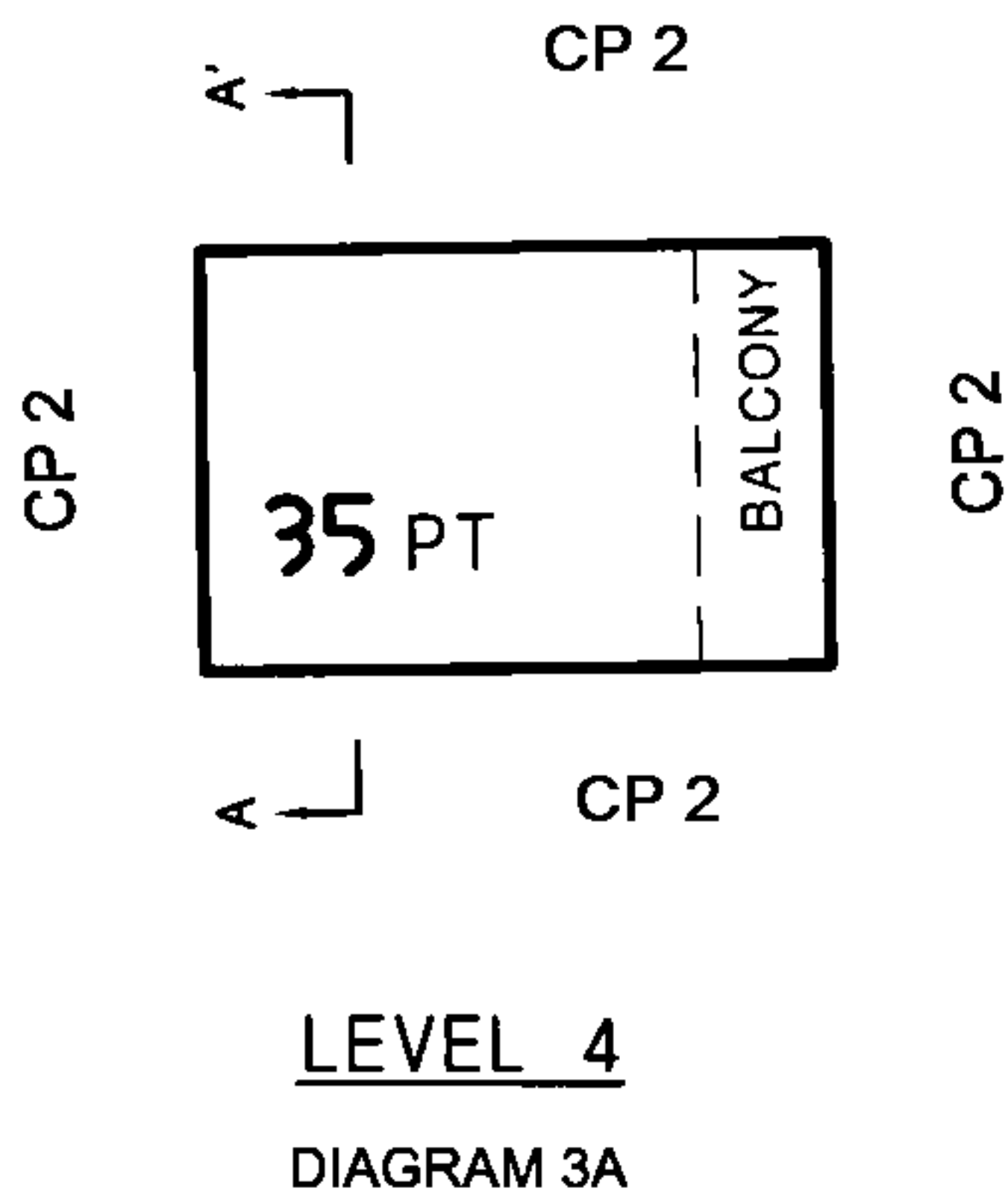
Plan Number
PS600696N

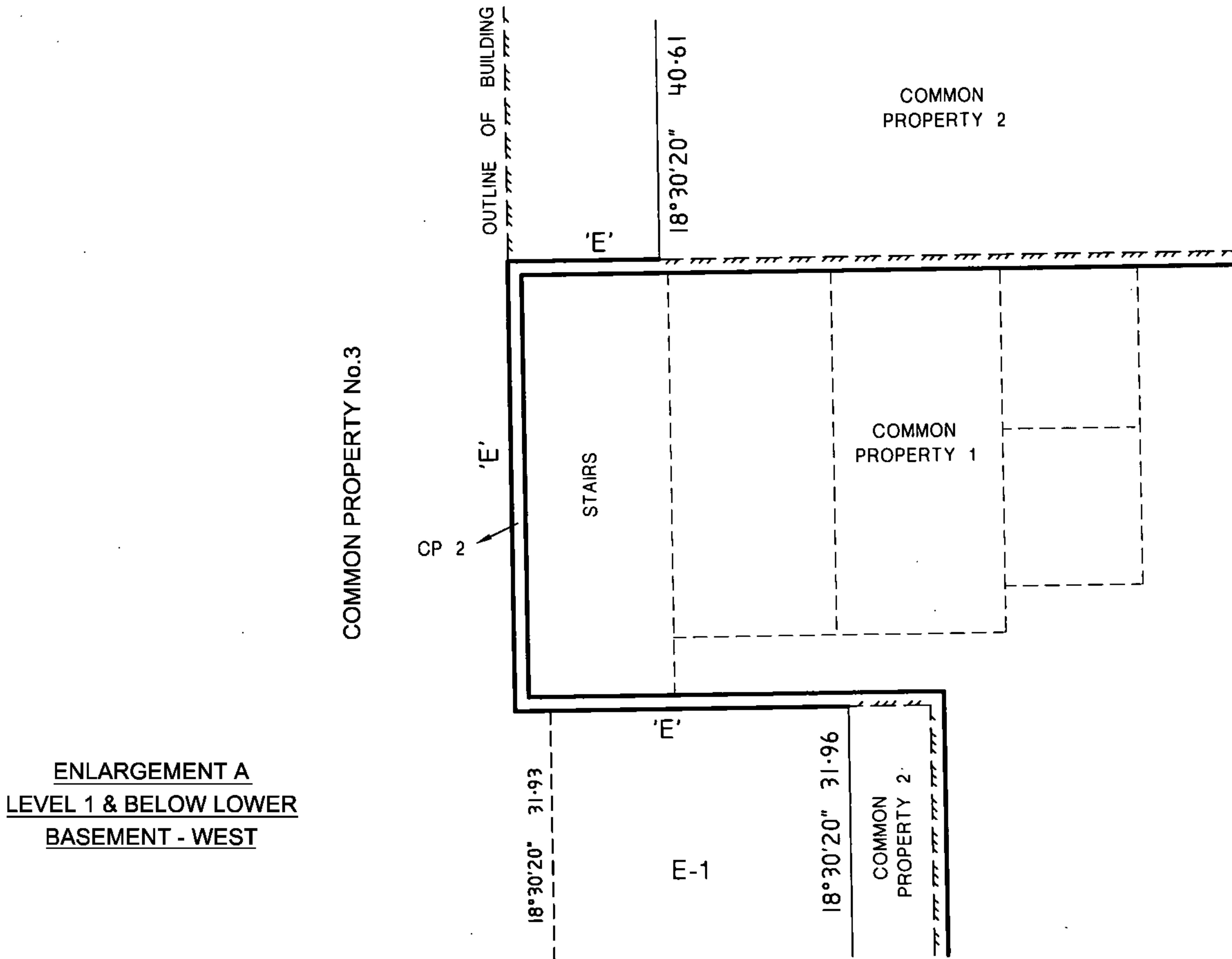

SCALE 1:300



SEE SHEET 3

TAYLORS 
DEVELOPMENT STRATEGISTS
PTY. LTD. A.B.N. 48 042 392 373
ISO9001 Certificate No 851
Land Surveying · Town Planning · Development Strategy · Project Co-ordination · Urban Design · G.I.S.
BUILDING B, 270 FERNTREE GULLY ROAD, NOTTING HILL 3168 Tel.9501 2800 Fax.9501 2844
Email: tds@taylorsds.com.au Web Site: www.taylorsds.com.au

Sheet 9

ORIGINAL
SCALE SHEET SIZE
A3

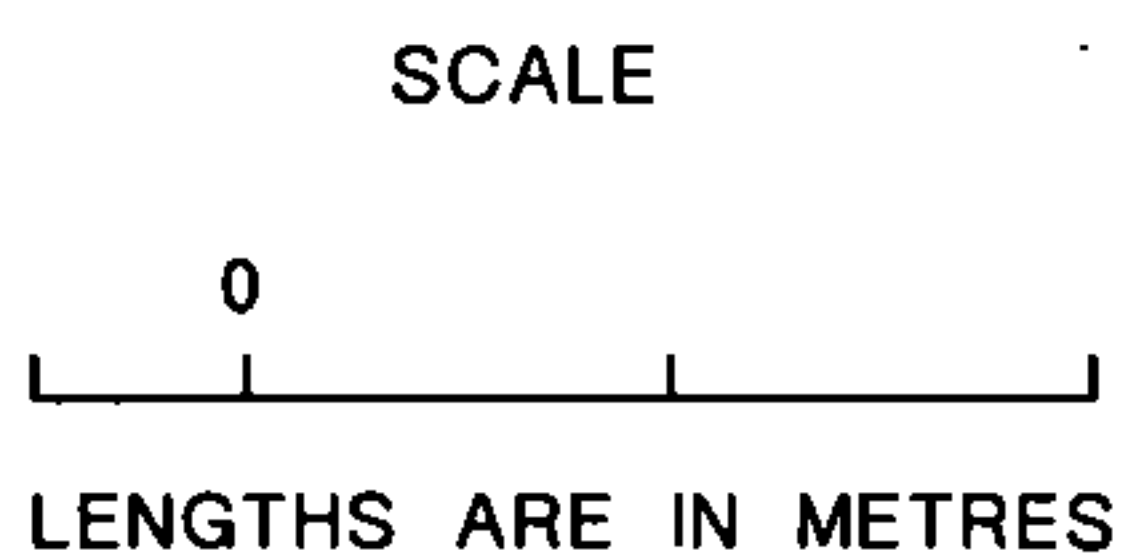

LICENSED SURVEYOR : NEIL OLIVER

Signature 

Date 19/6/09

REF. 9718-S1

VERSION 13 17/06/09 MFV

Date 25/06/09
Council Delegate Signature
Original sheet size A3

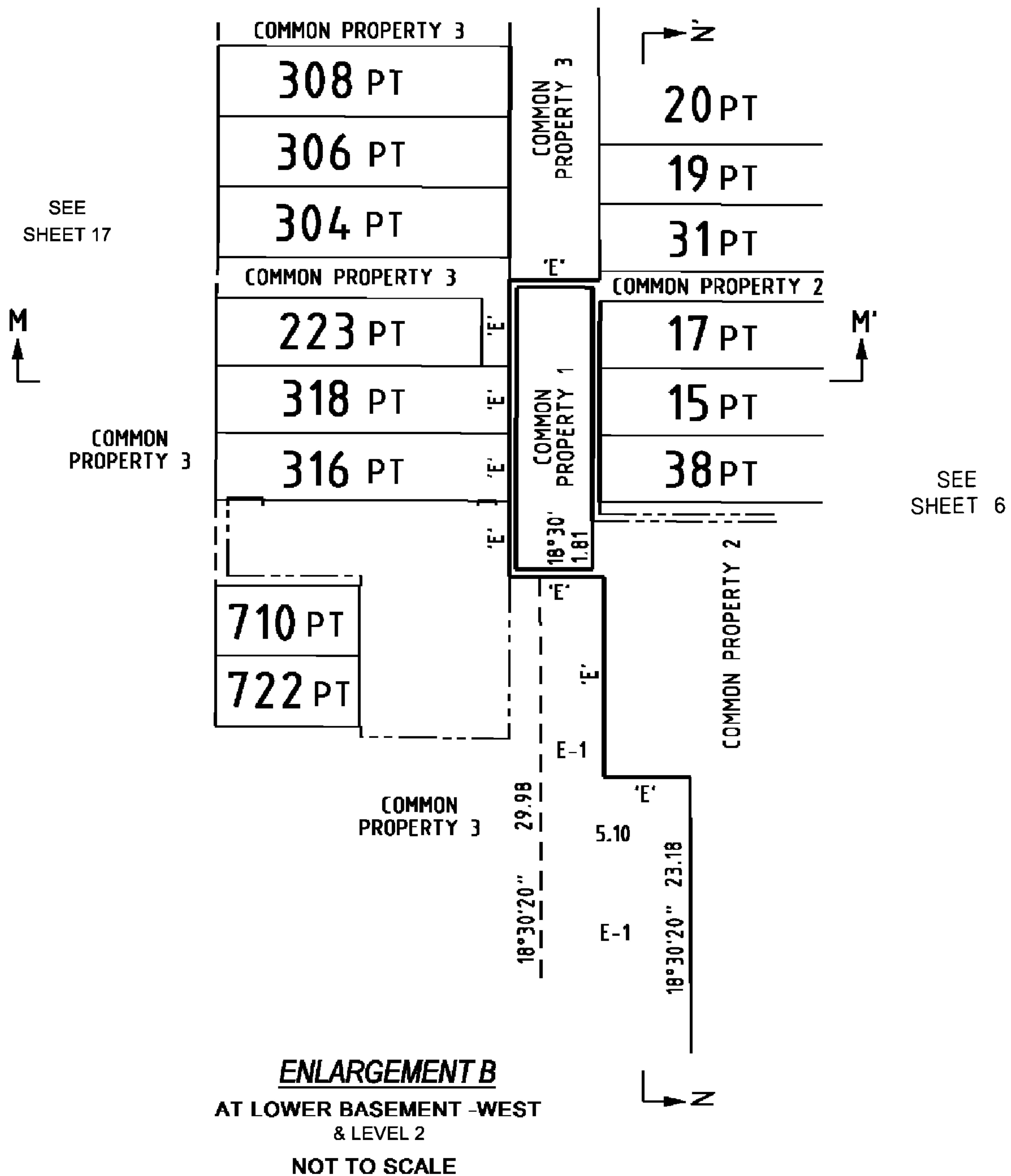

ENLARGEMENT B
AT LOWER BASEMENT -WEST
& LEVEL 2
NOT TO SCALE

TAYLORS 
DEVELOPMENT STRATEGISTS
PTV. LTD. A.B.N. 48 042 392 373
Land Surveying · Town Planning · Development Strategy · Project Co-ordination · Urban Design · G.I.S.
BUILDING 8, 270 FERNTREE GULLY ROAD, NOTTING HILL 3168 Tel.9501 2800 Fax.9501 2844
Email: tds@taylorsds.com.au Web Site: www.taylorsds.com.au

Sheet 10

ORIGINAL
SCALE SHEET SIZE
A3

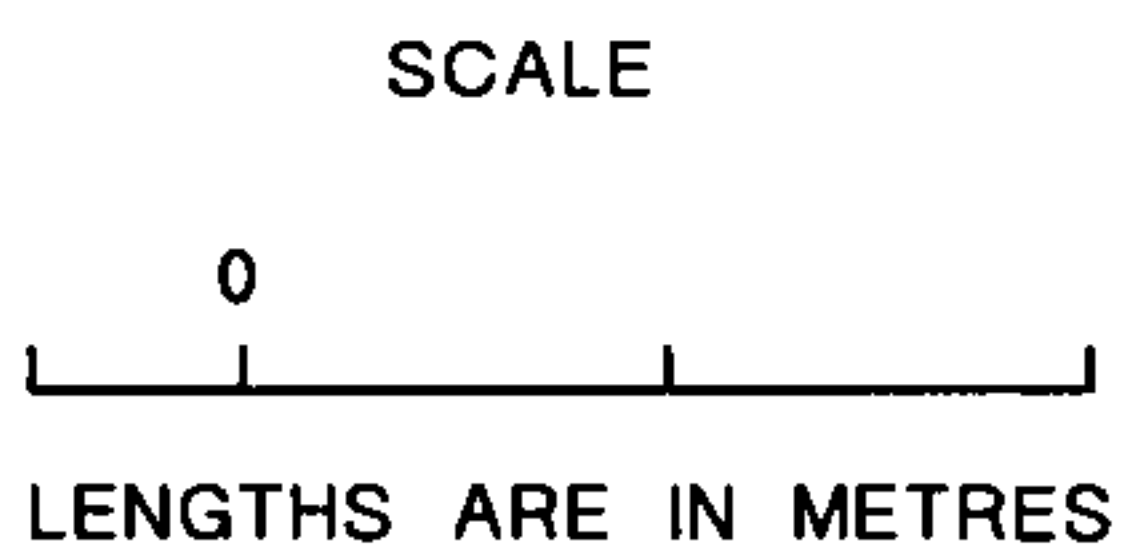

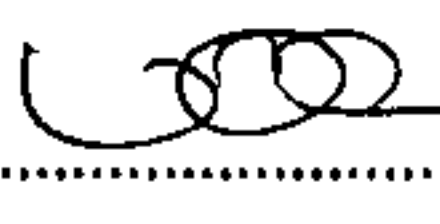
LICENSED SURVEYOR : NEIL OLIVER
Signature  Date 19/6/09
REF. 9718-S1 VERSION 13 17/06/09 MFV



Date 25/06/09
Council Delegate Signature
Original sheet size A3

PLAN OF SUBDIVISION

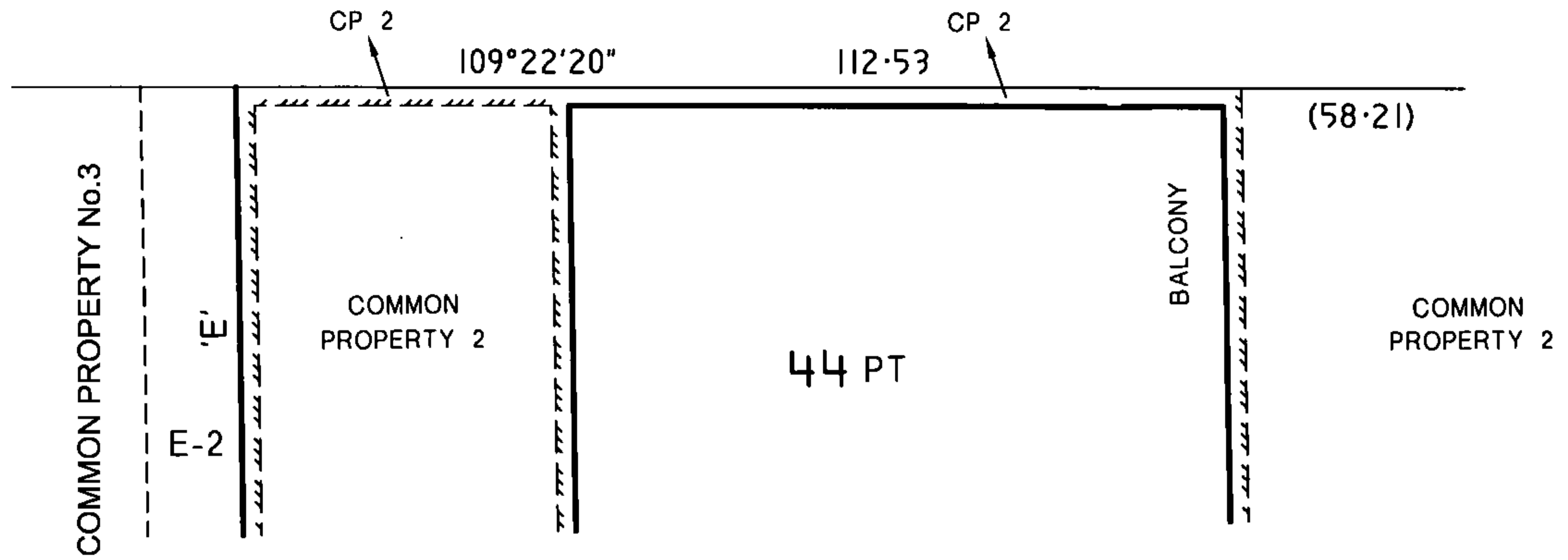
Plan Number
PS600696N

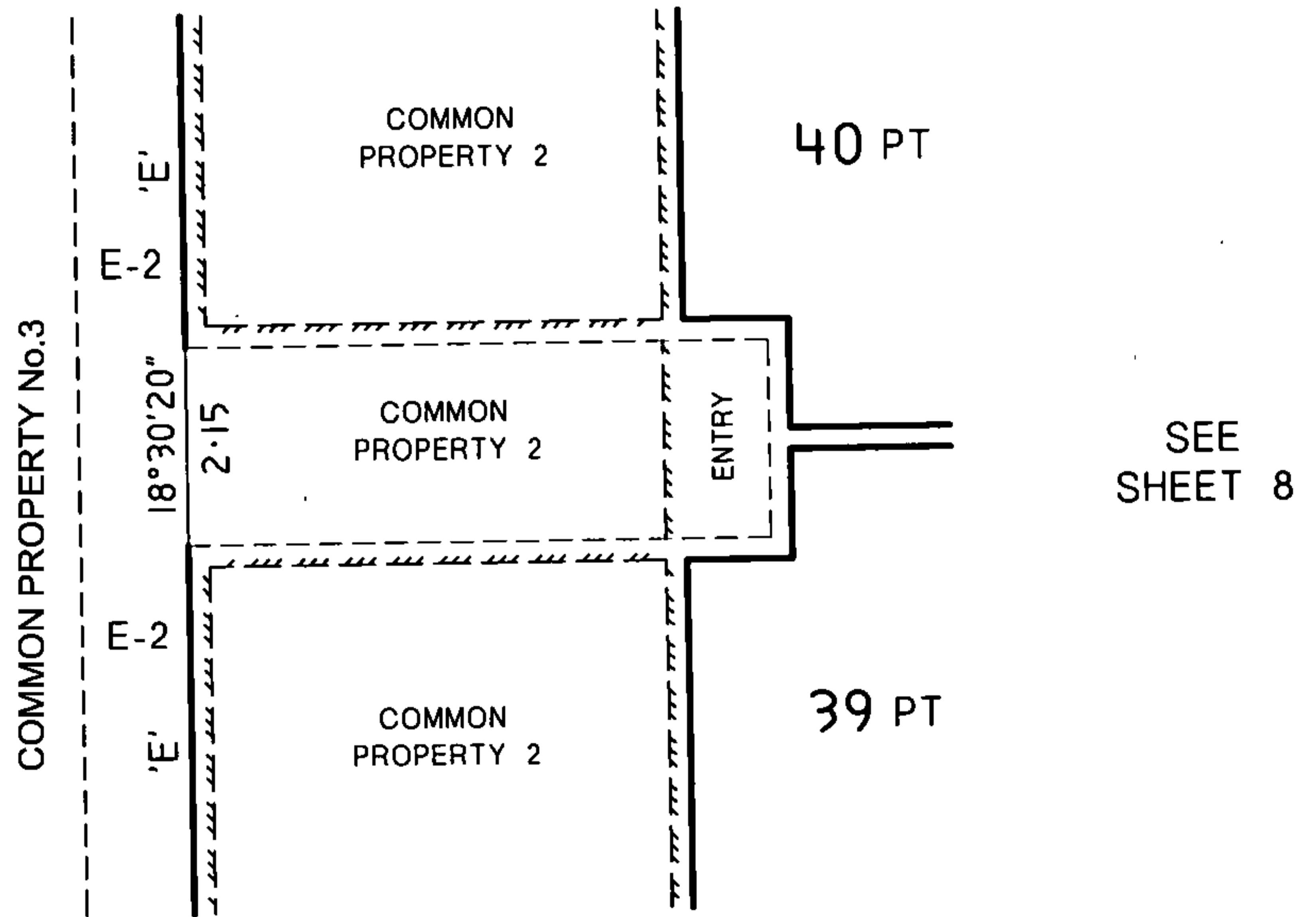

ENLARGEMENT C
LEVEL 3



ENLARGEMENT D
LEVEL 3

TAYLORS 
 DEVELOPMENT STRATEGISTS
ISO9001 Certificate No 851
 PTY. LTD. A.B.N 48 042 392 373
 Land Surveying · Town Planning · Development Strategy · Project Co-ordination · Urban Design · G.I.S.
 BUILDING 8, 270 FERNTREE GULLY ROAD, NOTTING HILL 3168 Tel.9501 2800 Fax.9501 2844
 Email: tds@taylorsds.com.au Web Site: www.taylorsds.com.au

Sheet 11

ORIGINAL
SCALE SHEET SIZE
1:300 A3

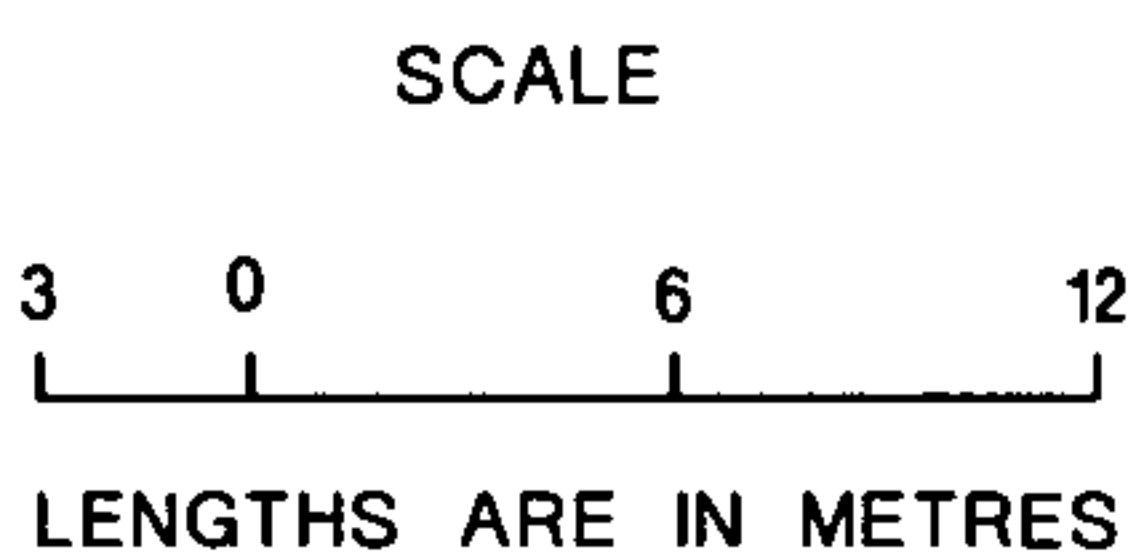

LICENSED SURVEYOR : NEIL OLIVER

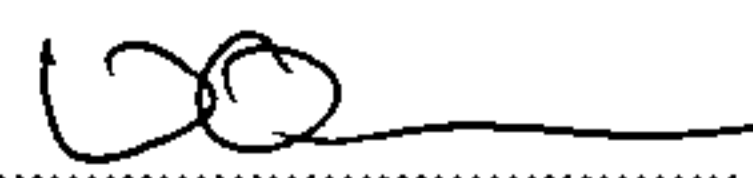
Signature  Date 19/6/09

REF. 9718-S1

VERSION 13 17/06/09 MFV

 Date 25/06/09
 Council Delegate Signature
 Original sheet size A3

PLAN OF SUBDIVISION

Plan Number
PS600696N

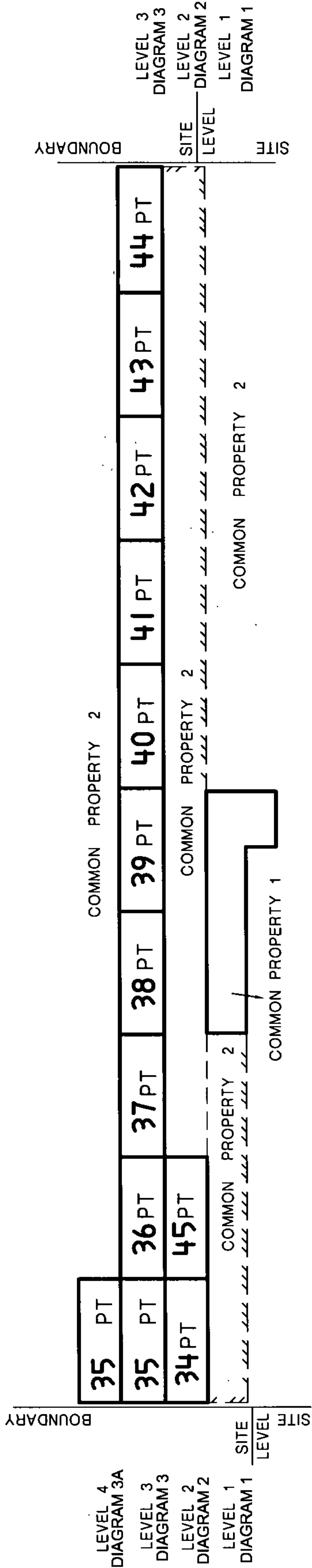

LEVEL 4
DIAGRAM 3A
LEVEL 3
DIAGRAM 3
LEVEL 2
DIAGRAM 2
LEVEL 1
DIAGRAM 1

LEVEL 3
DIAGRAM 3
LEVEL 2
DIAGRAM 2
LEVEL 1
DIAGRAM 1

SECTION A - A'
Not to Scale

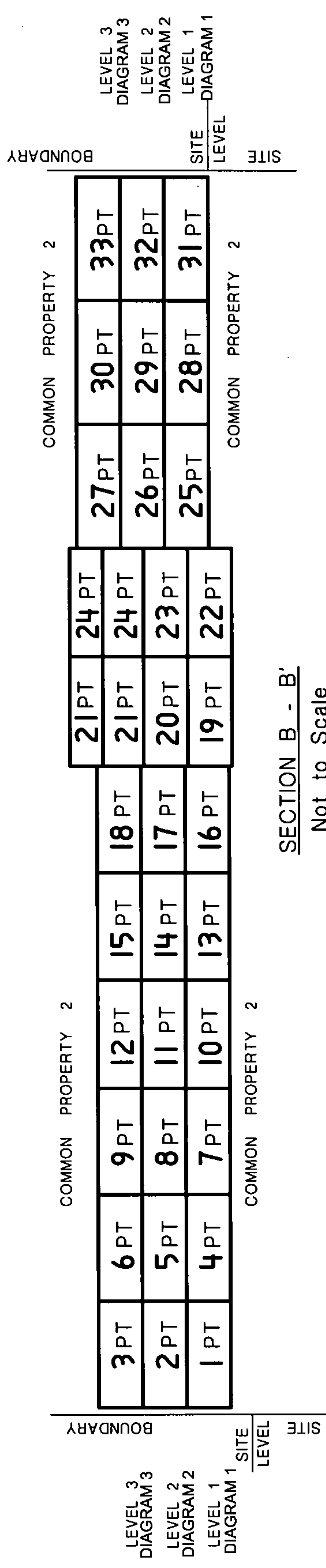

LEVEL 3
DIAGRAM 3
LEVEL 2
DIAGRAM 2
LEVEL 1
DIAGRAM 1

LEVEL 3
DIAGRAM 3
LEVEL 2
DIAGRAM 2
LEVEL 1
DIAGRAM 1

SECTION B - B'
Not to Scale

Sheet 12

TAYLORS
DEVELOPMENT STRATEGISTS
PTY. LTD. A.B.N. 48 042 392 373
Certified Valuers
Land Surveying · Town Planning · Development Strategy · Project Coordination · Urban Design · G.I.S.
BUILDING 8, 270 FERRITREE GULLY ROAD, NOTTING HILL 3168 Tel: 9501 2800 Fax: 9601 2844
Email: tds@taylors.com.au Web Site: www.taylors.com.au

ORIGINAL SCALE SHEET SIZE A3

SCALE
0
LENGTHS ARE IN METRES

LICENSED SURVEYOR : NEIL OLIVER
Signature: *[Signature]* Date: 19/6/09
REF. 9718-S1 VERSION 13 17/06/09 MFV

Council Delegate Signature
Date 25/06/09
Original sheet size A3

PLAN OF SUBDIVISION

Plan Number
PS600696N

* NOTE: PROJECTION OF
UNDERSIDE OF FLOOR SLAB

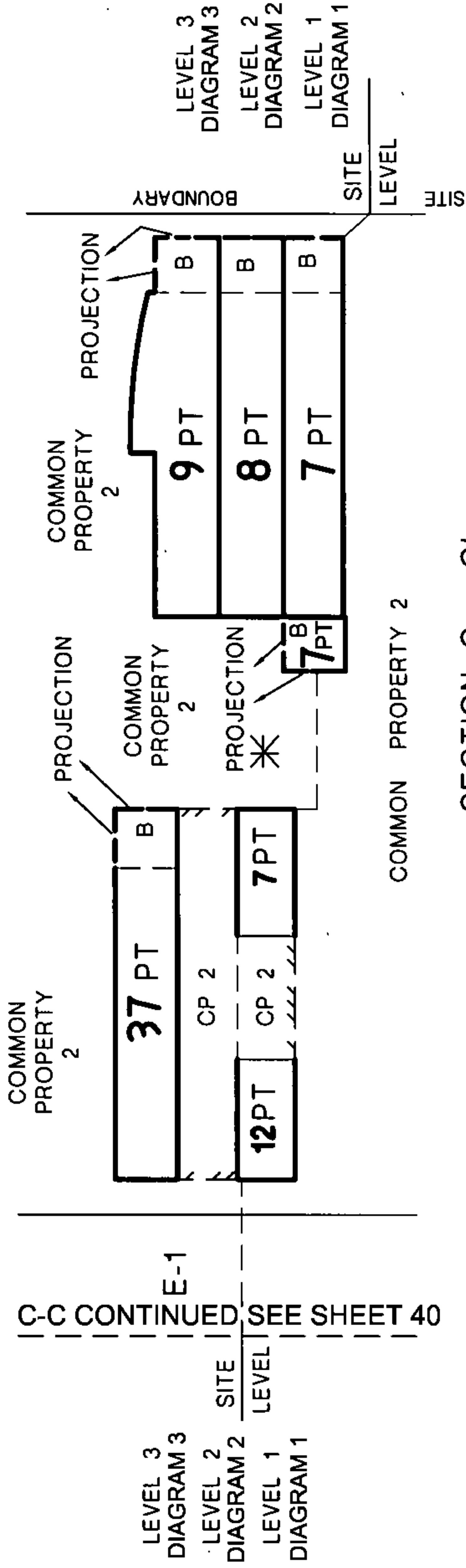

SECTION C - C'

Not to Scale

NOTE
LOWER BOUNDARY OF E-2
IS PROJECTION OF LEVEL
3 FLOOR SLAB

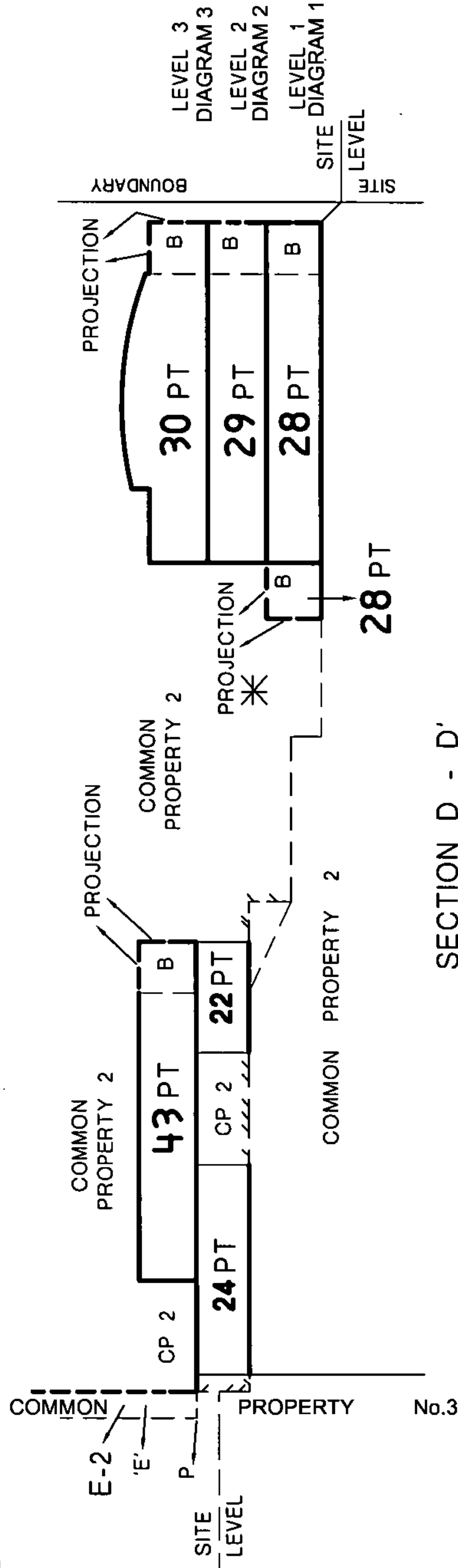

SECTION D - D'

Not to Scale

Sheet 13

TAYLORS
DEVELOPMENT STRATEGISTS
Pty. Ltd. A.B.N. 48 042 392 373
Land Surveying · Town Planning · Development Strategy · Project Co-ordination · Urban Design · G.I.S.
BUILDING 8, 270 FERNTREE GULLY ROAD, NOTTING HILL 3168 Tel: 9501 2800 Fax: 9501 2844
Email: tds@taylors.com.au Web Site: www.taylors.com.au

| | |
|----------------|------------|
| ORIGINAL SCALE | SHEET SIZE |
| | A3 |

SCALE
0
LENGTHS ARE IN METRES

LICENSED SURVEYOR : NEIL OLIVER
Signature *[Signature]* Date 19/6/09
REF. 9718-S1 VERSION 13 17/06/09 MFV

[Signature]
Date 25/06/09
Council Delegate Signature
Original sheet size A3

PLAN OF SUBDIVISION

Plan Number

PS600696N

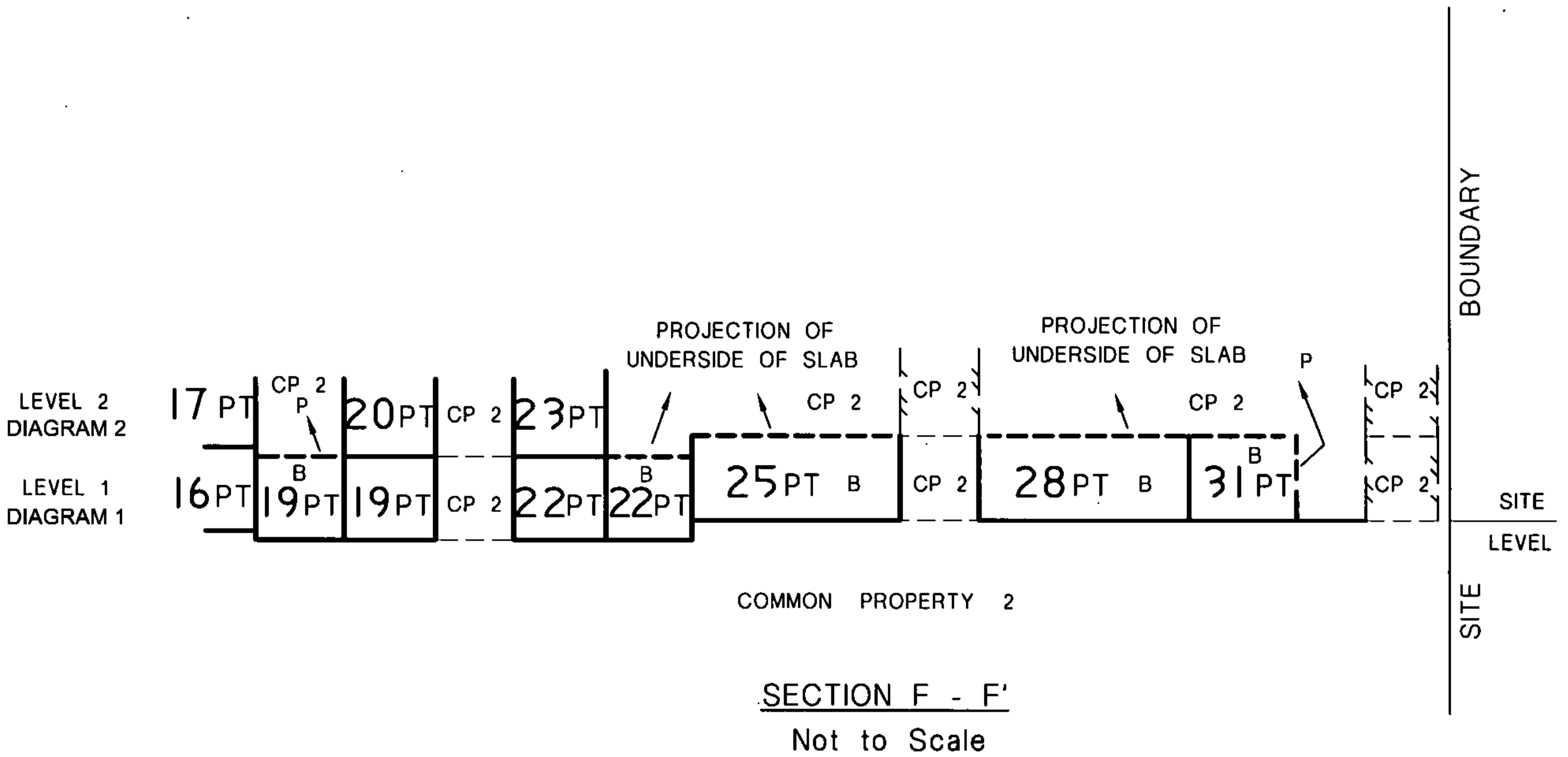
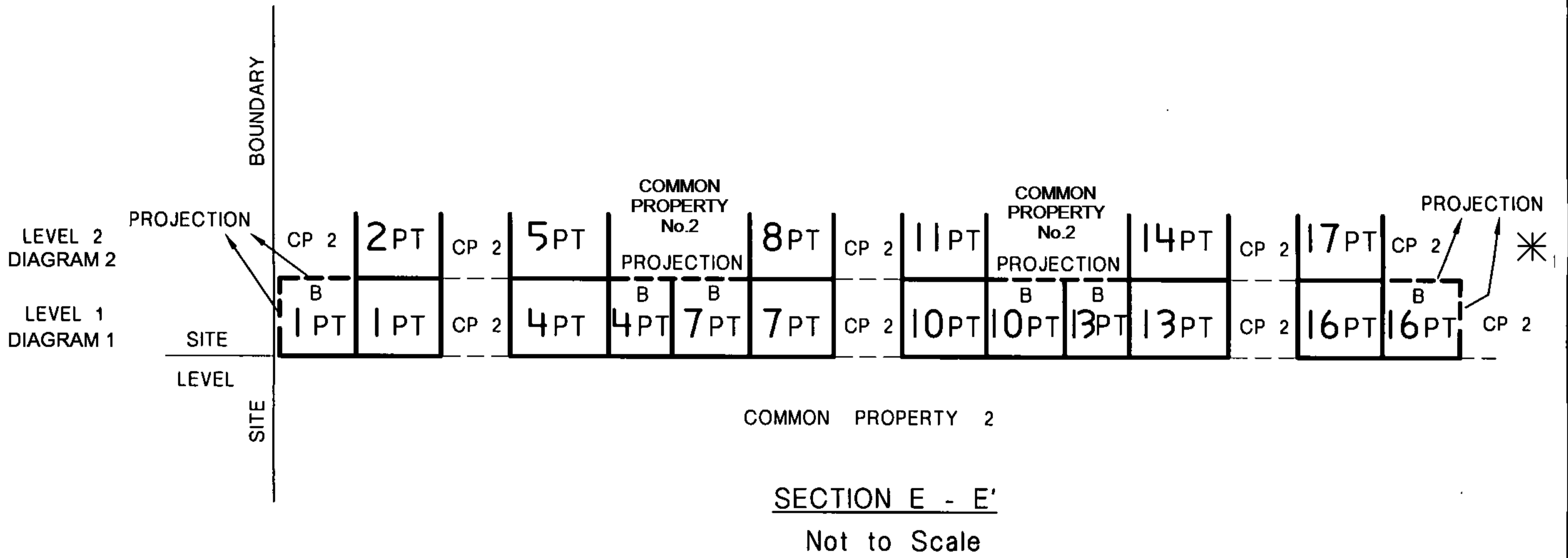



TAYLORS 
 DEVELOPMENT STRATEGISTS
 PTY. LTD. A.B.N. 48 042 392 373
 Land Surveying · Town Planning · Development Strategy · Project Co-ordination · Urban Design · GIS
 BUILDING 8, 270 FERNTREE GULLY ROAD, NOTTING HILL 3168 Tel.9501 2800 Fax.9501 2844
 Email: lds@taylorsds.com.au Web Site: www.taylorsds.com.au

Sheet 14

ORIGINAL
SCALE SHEET SIZE
1:300 A3

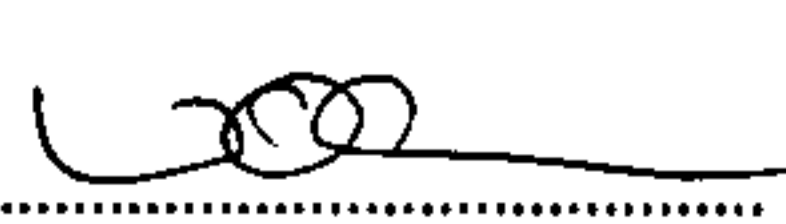
SCALE
3 0 6 12
LENGTHS ARE IN METRES

LICENSED SURVEYOR : NEIL OLIVER
Signature  Date 19, 6, 09
REF. 9718-S1 VERSION 13 17/06/09 MFV

Date 25, 06, 09
Council Delegate Signature
Original sheet size A3

PLAN OF SUBDIVISION

Plan Number
PS600696N

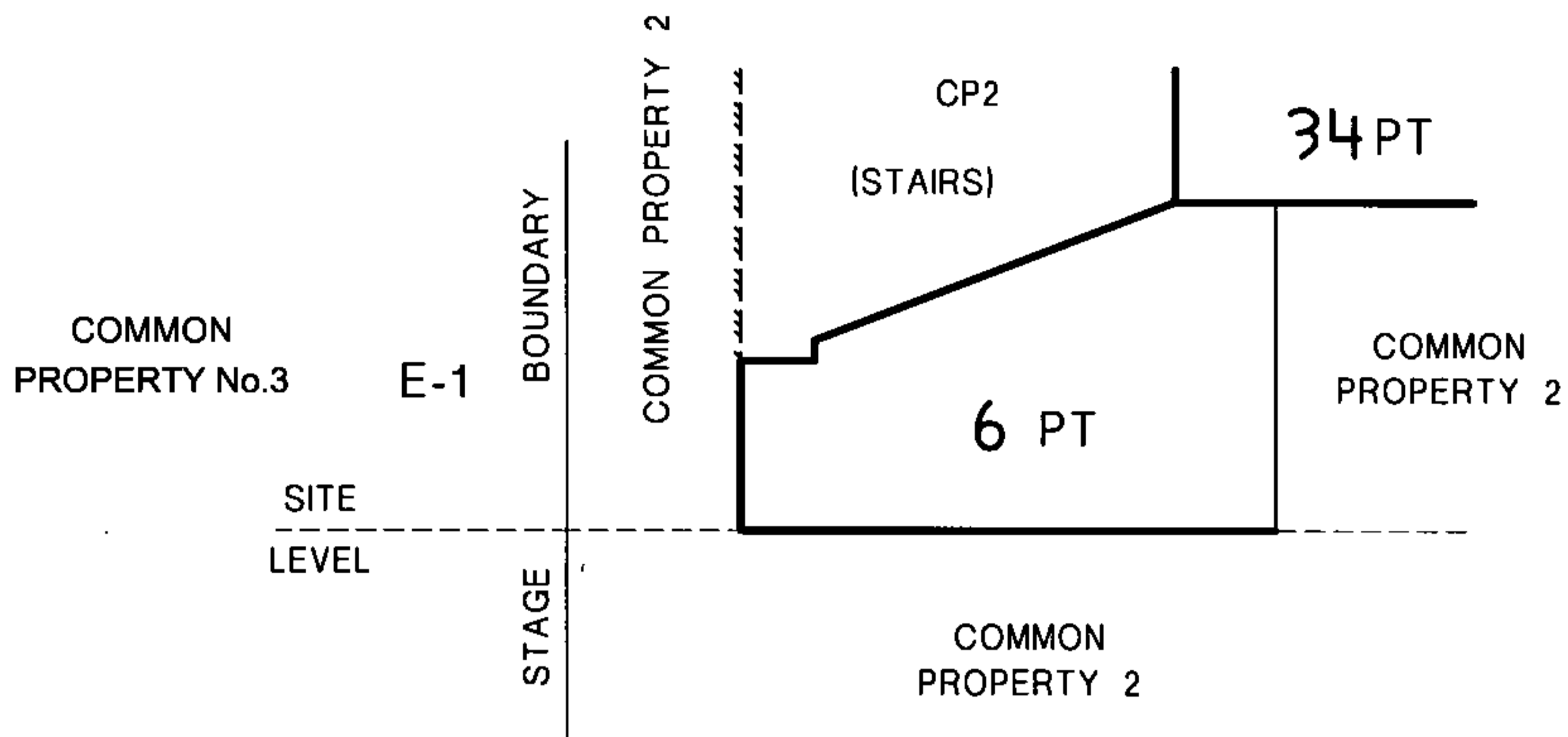

SECTION G - G'

Not to Scale

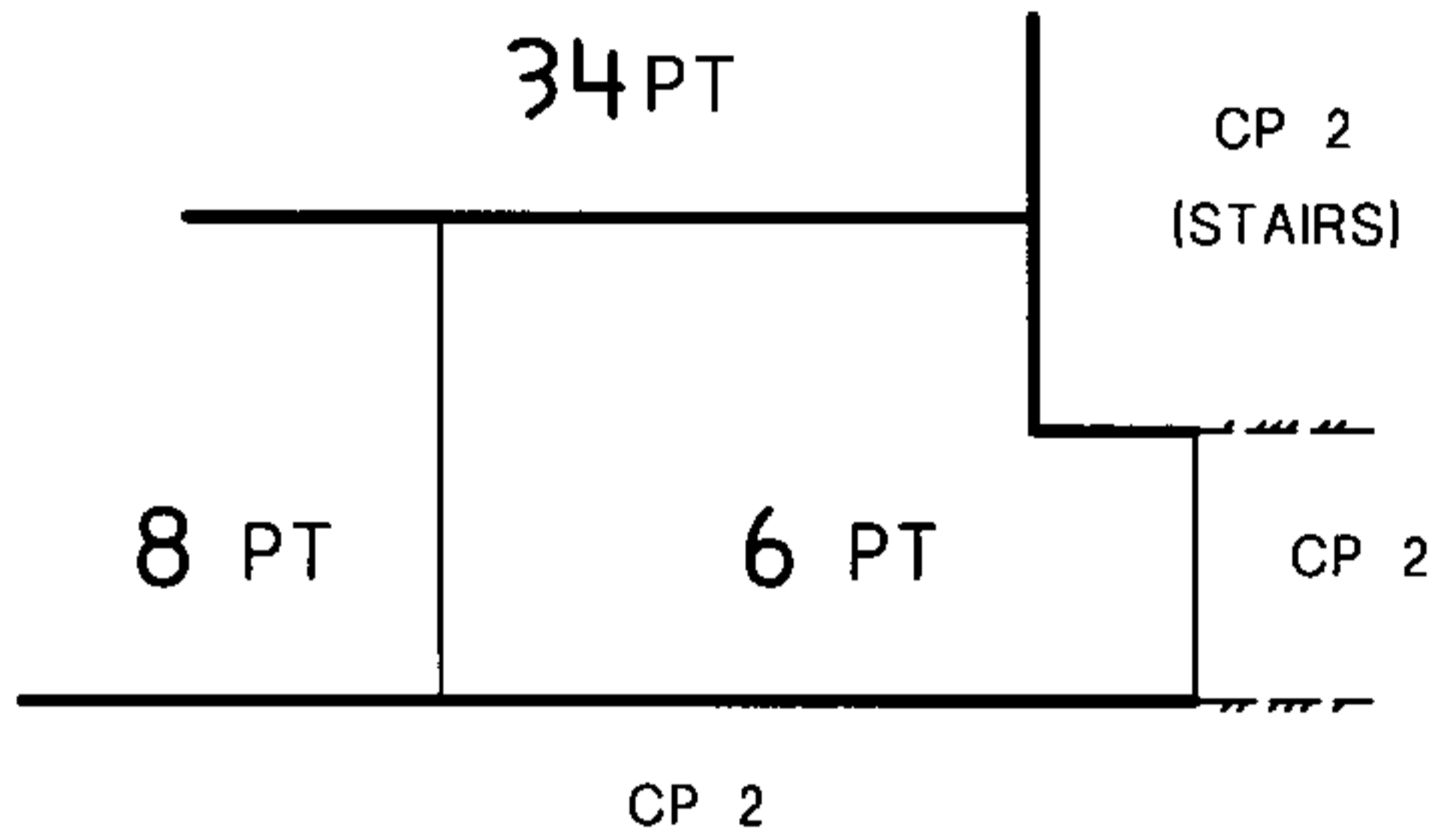

SECTION H - H'

Not to Scale

TAYLORS 
 DEVELOPMENT STRATEGISTS
 PTY. LTD. A.B.N. 48 042 392 373
 ISO9001 Certificate No 851
 Land Surveying · Town Planning · Development Strategy · Project Co-ordination · Urban Design · GIS
 BUILDING 8, 270 FERNTREE GULLY ROAD, NOTTING HILL 3168 Tel.9501 2800 Fax.9501 2844
 Email: tds@taylorsds.com.au Web Site: www.taylorsds.com.au

Sheet 15

ORIGINAL
SCALE SHEET SIZE
1:300 A3

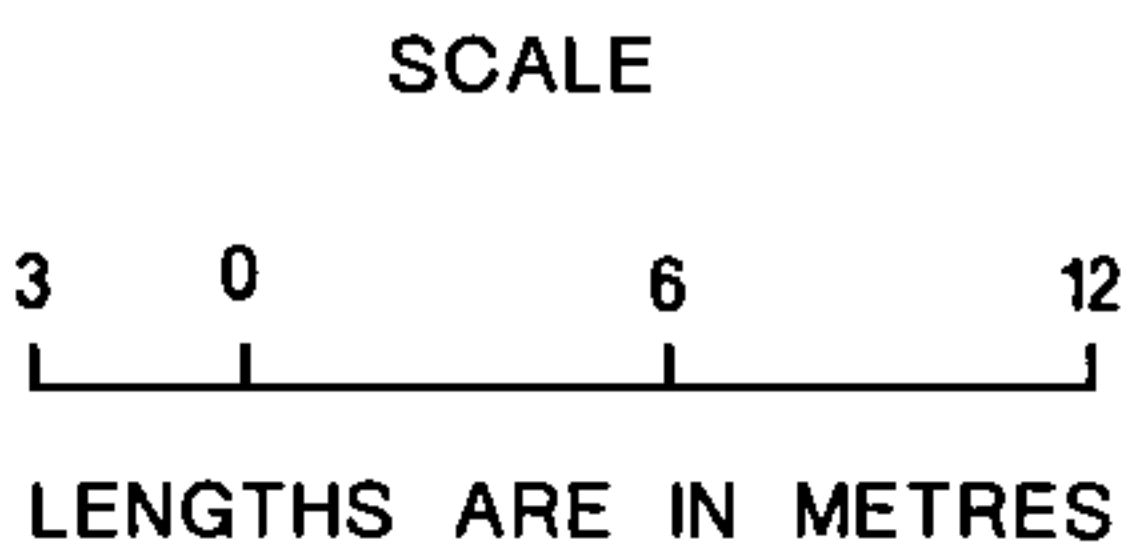

LICENSED SURVEYOR : NEIL OLIVER

Signature 

Date 19, 6, 09

REF. 9718-S1

VERSION 13 17/06/09 MFV



 Date 25, 06, 09
 Council Delegate Signature
 Original sheet size A3

SITE DIAGRAM & LEVEL 1-WEST

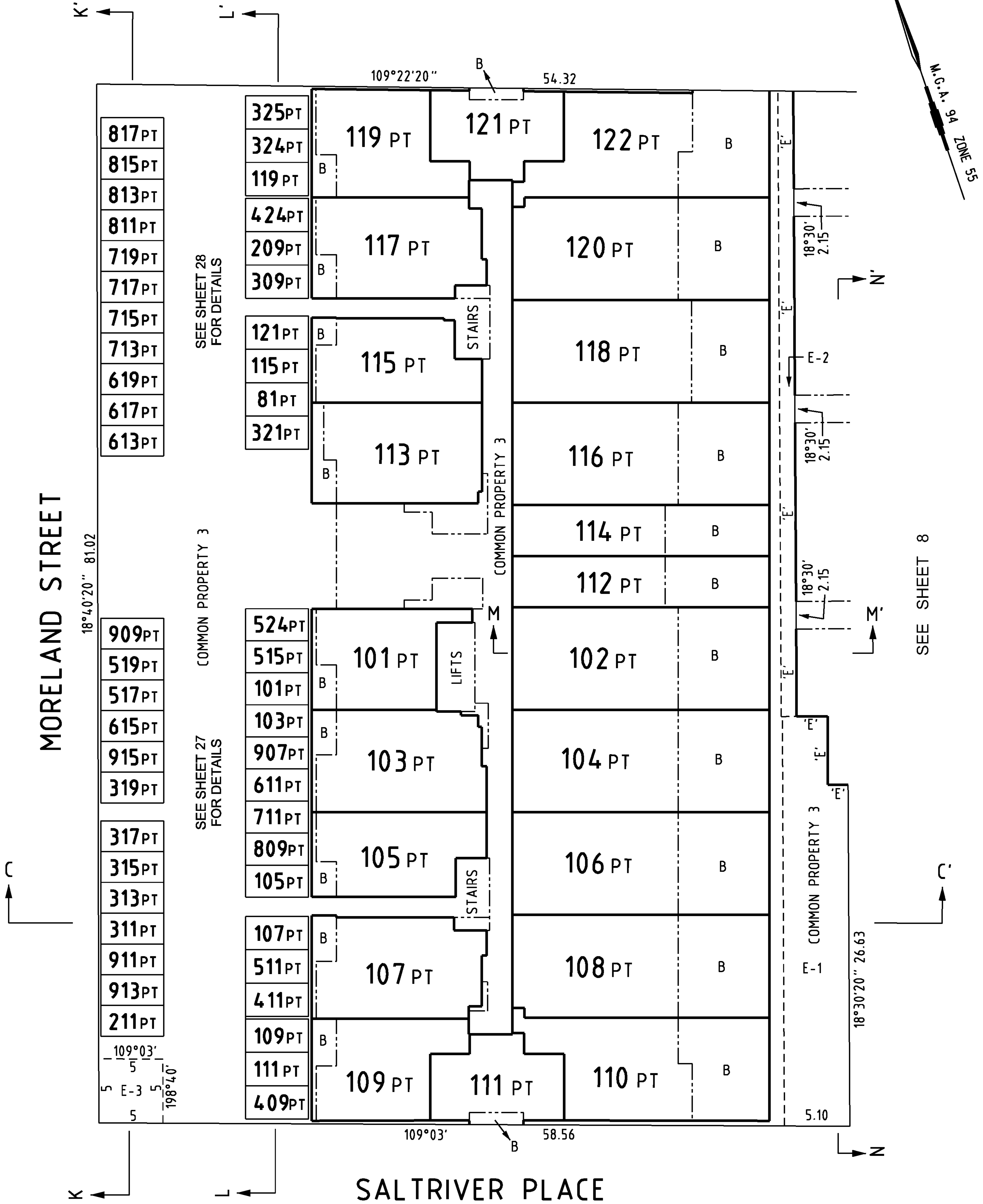
DIAGRAM 4

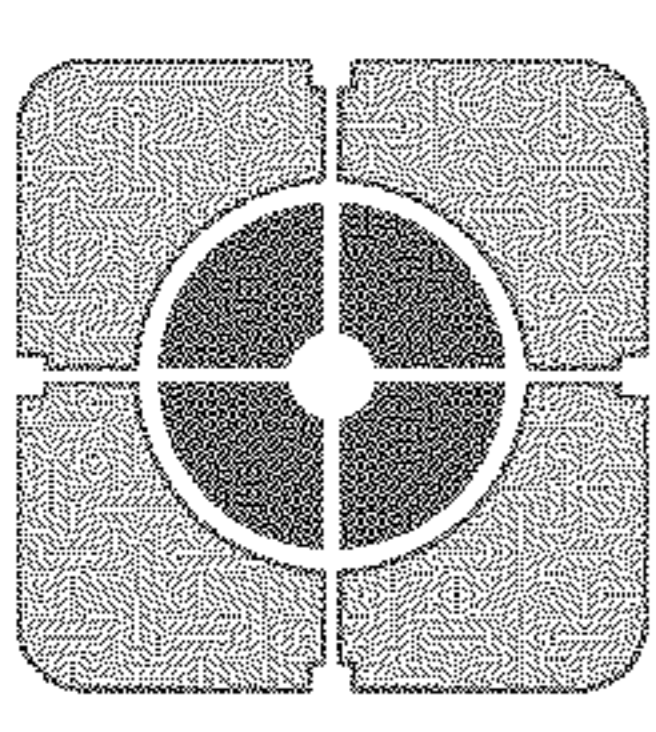

SEE SHEET 8



Peninsula Survey Group PTY LTD
 Consulting Land Surveyors
 24A Progress Street, Mornington, VIC. 3931.
 Phone: 9787 2980 mail@peninsulasurvey.com.au
 ACN 067 077 614

FILE REF: 6241 / PS

SCALE
 1: 300



ORIGINAL
 SHEET SIZE: A3

SHEET 16

Digitally signed by: Alan Leslie Runting (Peninsula Survey Group Pty Ltd),
 Surveyor's Plan Version (4.1),
 15/11/2016 Amended: 16/12/2016

Digitally signed by:
 Maribyrnong City Council,
 16/11/2016,
 SPEAR Ref: S085223M

LOWER BASEMENT-WEST
DIAGRAM 5

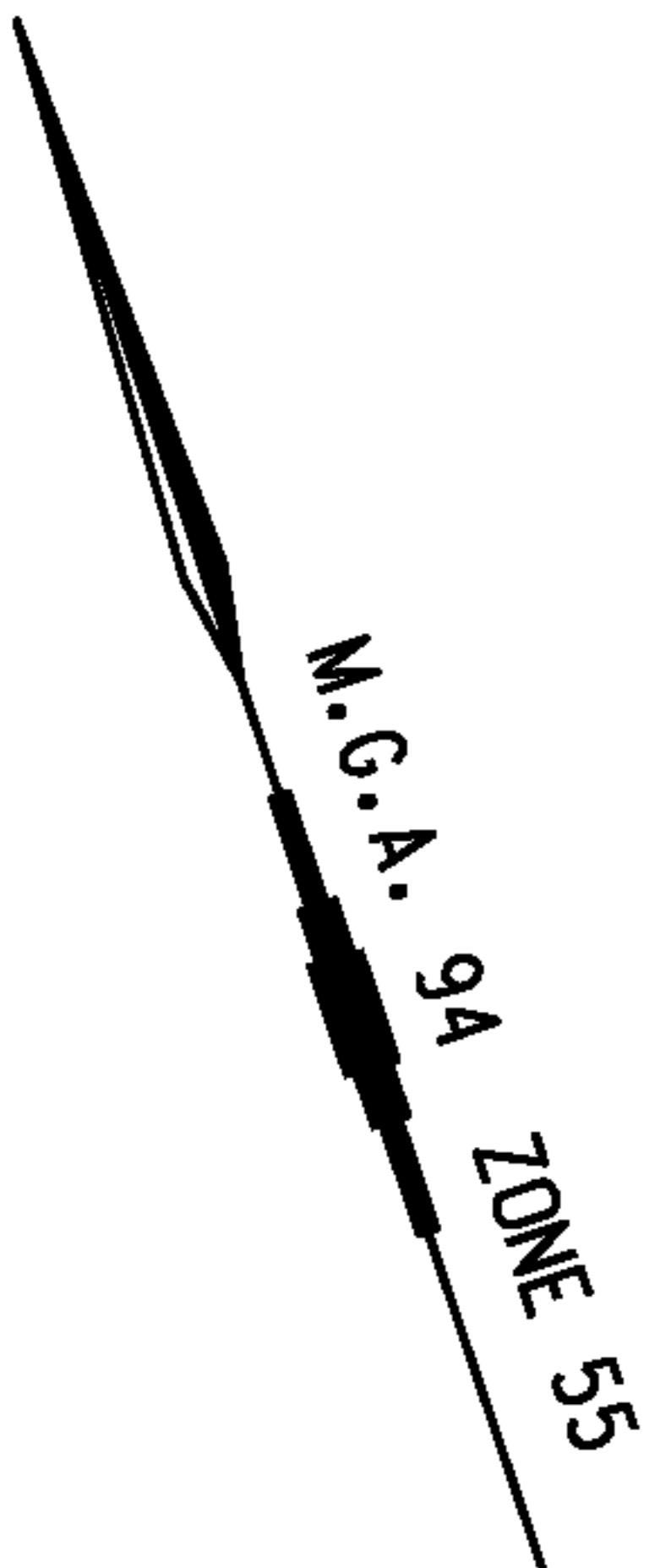
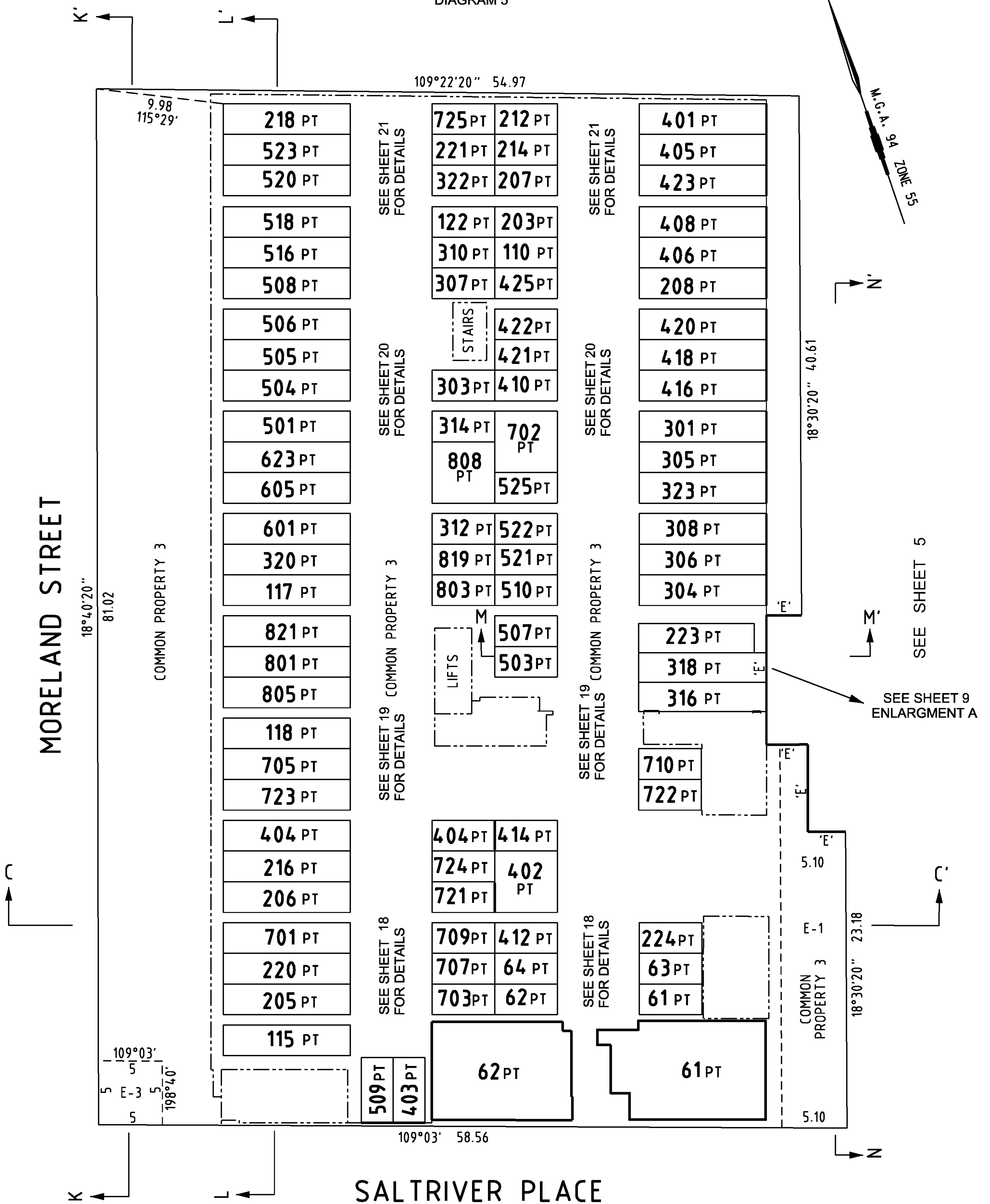

SEE SHEET 9 ENLARGMENT A

SEE SHEET 5

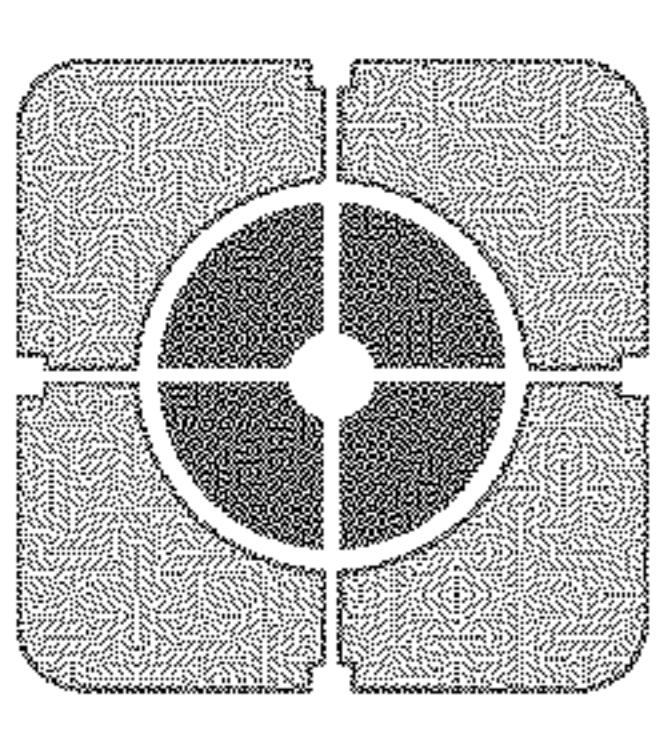

Peninsula Survey Group PTY LTD
Consulting Land Surveyors
24A Progress Street, Mornington, VIC. 3931.
Phone: 9787 2980 mail@peninsulasurvey.com.au
ACN 067 077 614

FILE REF: 6241 / PS

SCALE
1: 300



ORIGINAL SHEET SIZE: A3

SHEET 17

Digitally signed by: Alan Leslie Runting (Peninsula Survey Group Pty Ltd),
Surveyor's Plan Version (4.1),
15/11/2016 Amended: 16/12/2016

Digitally signed by:
Maribyrnong City Council,
16/11/2016,
SPEAR Ref: S085223M

PS 600696N

LOWER BASEMENT - WEST

SEE SHEET 19

M.G.A. 94 ZONE 55

COMMON PROPERTY 3

COMMON PROPERTY 3

COMMON PROPERTY 3

COMMON PROPERTY 3

COMMON PROPERTY 3

COMMON PROPERTY 3

COMMON PROPERTY 3

723 PT

COMMON PROPERTY 3

404 PT
108°47' 9.95
108°47' 9.95

216 PT

206 PT
108°47' 9.95
108°47' 9.95

701 PT

220 PT
108°47' 9.95
108°47' 9.95

205 PT

115 PT
108°47' 9.95
108°47' 9.95

0.80

2.40

2.40

2.40

2.40

2.40

2.40

2.40

108°47'

4.80

108°47'

724 PT

108°47' 4.90

721 PT

108°47' 4.80

709 PT

108°47' 4.90

707 PT

108°47' 4.90

703 PT

4.90

108°47'

4.80

108°47'

414 PT

108°47' 4.90

402 PT

108°47' 4.80

412 PT

108°47' 4.90

64 PT

108°47' 4.90

62 PT

4.90

108°47'

4.80

108°47'

2.40

2.40

2.40

2.40

2.40

2.40

2.40

2.40

2.40

108°47'

4.90

108°47'

224 PT

108°47' 4.90

63 PT

108°47' 4.90

61 PT

108°47' 4.90

2.40

2.40

2.40

61 PT

108°47'

4.90

108°47'

2.40

2.40

2.40

2.40

2.40

2.40

2.40

2.40

2.40

108°47'

4.80

108°47'

2.40

2.40

2.40

2.40

2.40

2.40

2.40

2.40

2.40

62 PT

108°47'

4.80

108°47'

2.40

2.40

2.40

2.40

2.40

2.40

2.40

2.40

2.40

62 PT

108°47'

4.80

108°47'

2.40

2.40

2.40

2.40

2.40

2.40

2.40

2.40

2.40

62 PT

108°47'

4.80

108°47'

2.40

2.40

2.40

2.40

2.40

2.40

2.40

2.40

2.40

62 PT

109°03' 58.56

SALTRIVER PLACE

Peninsula Survey Group
PTY LTD
Consulting Land Surveyors
24A Progress Street, Mornington, VIC. 3931.
Phone: 9787 2980 mail@peninsulasurvey.com.au
ACN 067 077 614

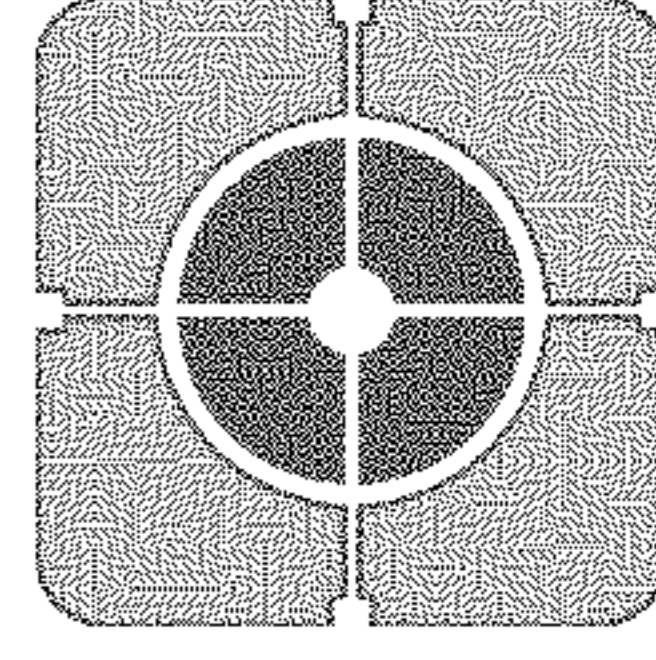

FILE REF: 6241 / PS

SCALE
1: 125

1.25 0 1.25 2.5 3.75 5
LENGTHS ARE IN METRES

ORIGINAL SHEET
SIZE: A3

SHEET 18

Digitally signed by:
Maribyrnong City Council,
16/11/2016,
SPEAR Ref: S08523M

Digitally signed by: Alan Leslie Runting (Peninsula Survey
Group Pty Ltd),
Surveyor's Plan Version (4.1),
15/11/2016 Amended: 16/12/2016

PS 600696N

LOWER BASEMENT - WEST

SEE SHEET 20

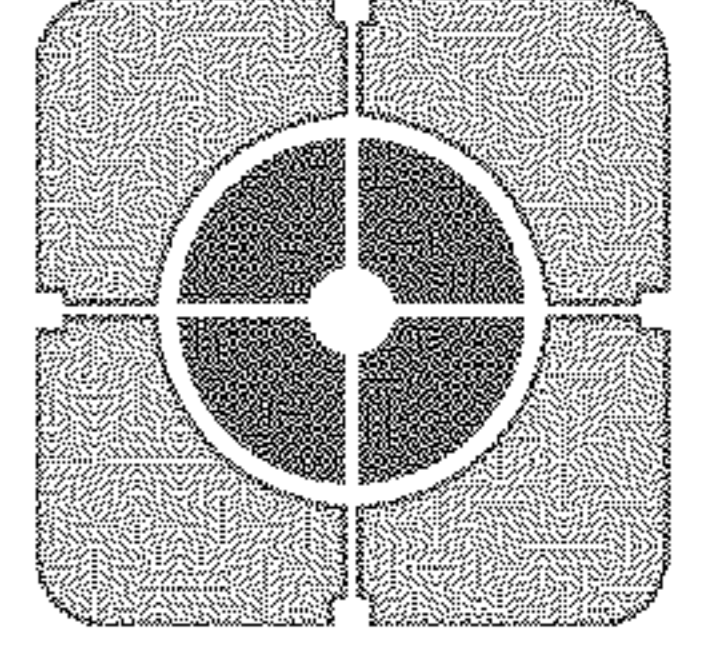
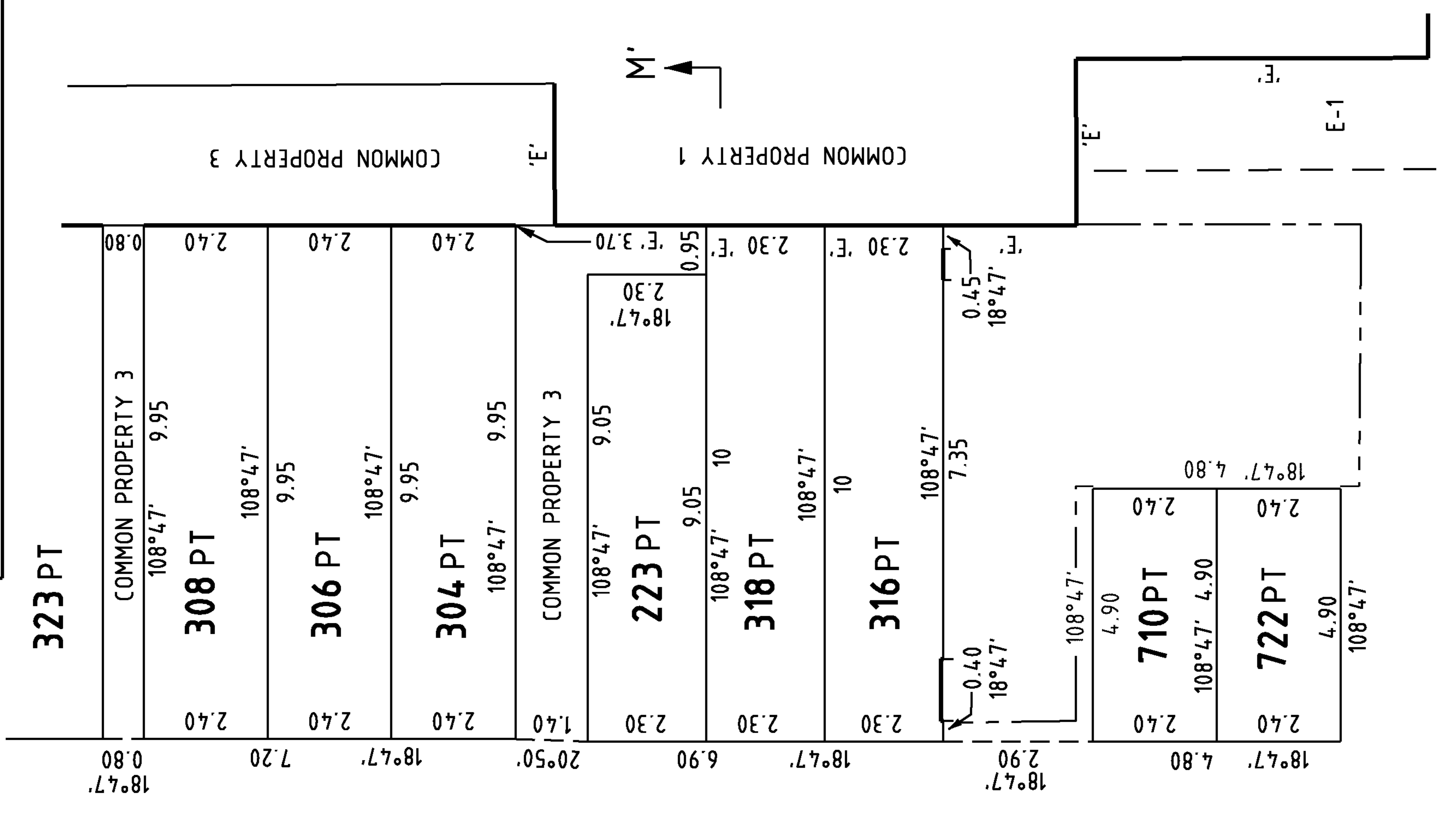
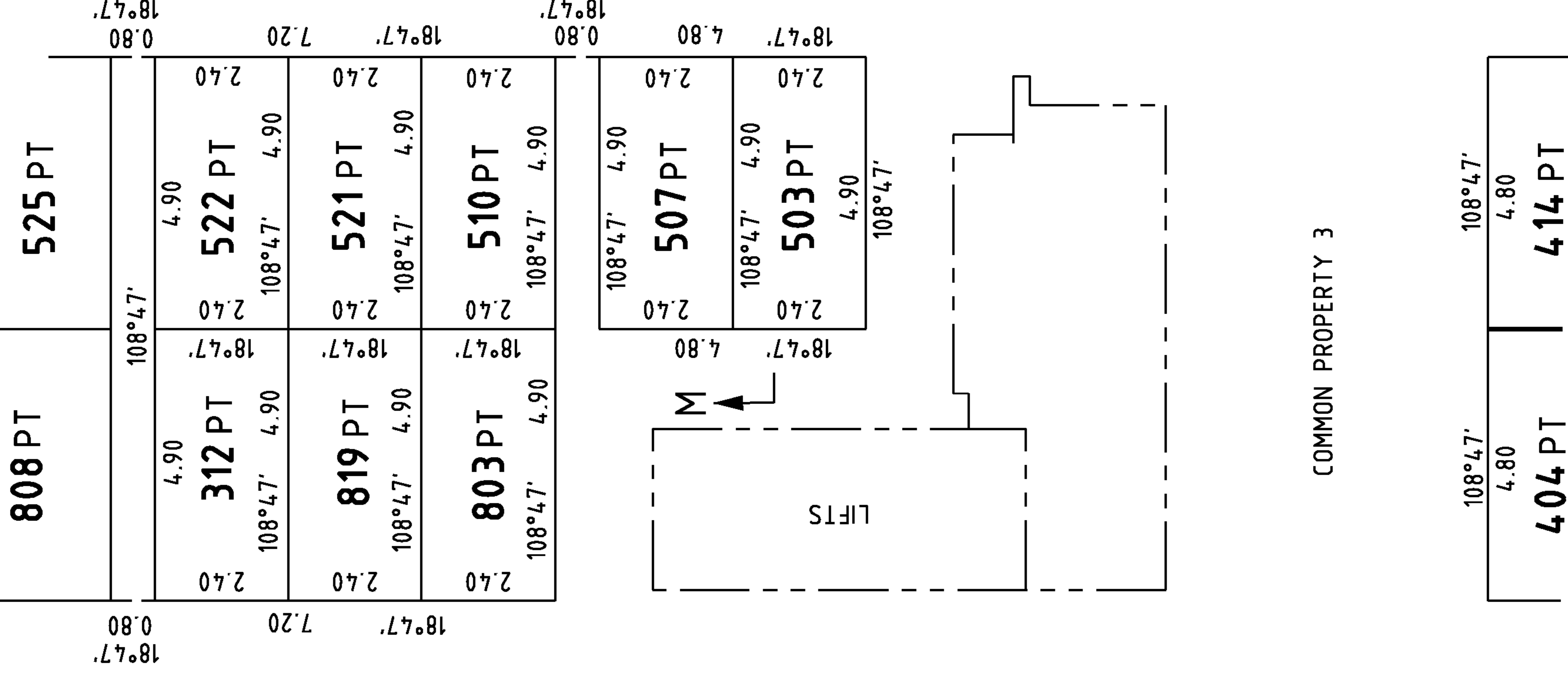
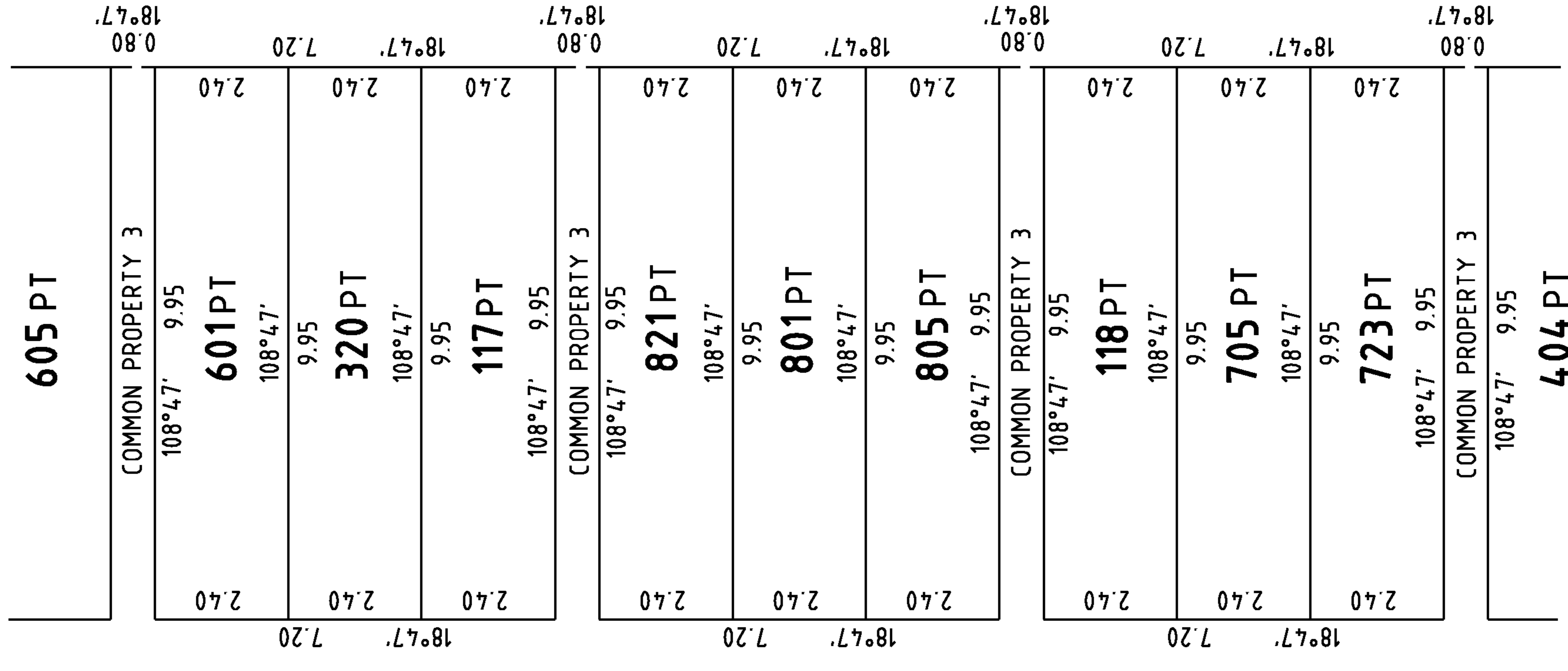
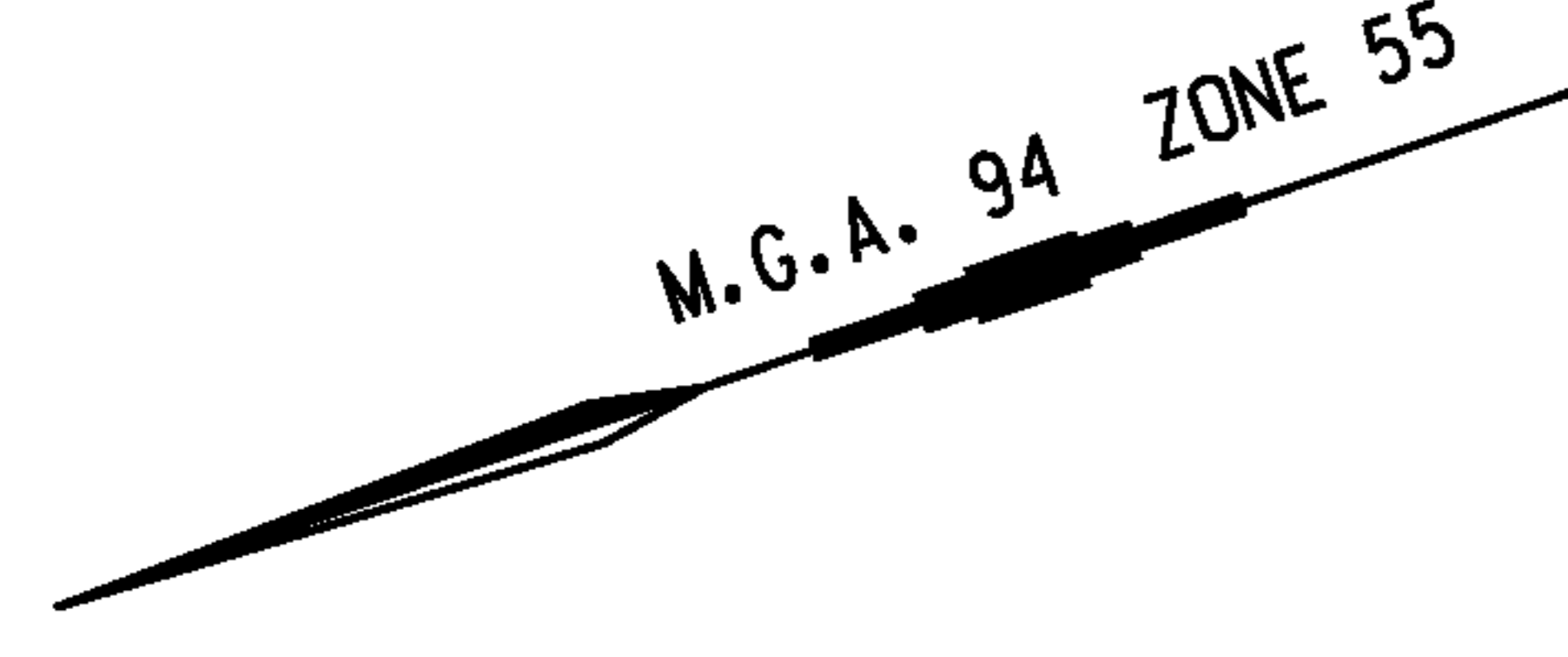

Peninsula Survey Group PTY LTD
Consulting Land Surveyors
 24A Progress Street, Mornington, VIC. 3931.
 Phone: 9787 2980 mail@peninsulasurvey.com.au
 ACN 067 077 614

FILE REF: 6241 / PS

SEE SHEET 18

SCALE
1: 125

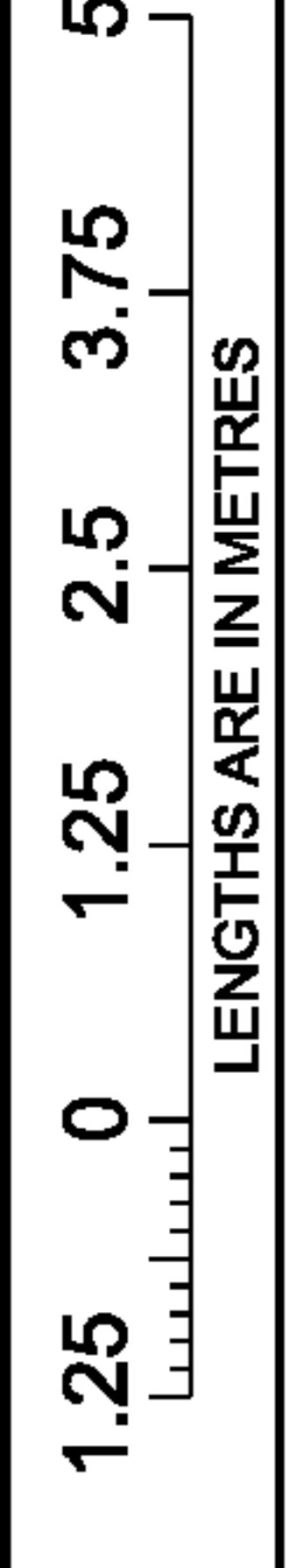

ORIGINAL SHEET
SIZE: A3

SHEET 19

Digitally signed by: Alan Leslie Runting (Peninsula Survey Group Pty Ltd),
 Surveyor's Plan Version (4.1),
 15/11/2016 Amended: 16/12/2016

Digitally signed by:
 Maribyrnong City Council,
 16/11/2016,
 SPEAR Ref: S085223M

PS 600696N

LOWER BASEMENT - WEST

SEE SHEET 21

M.G.A. 94 ZONE 55



SEE SHEET 19

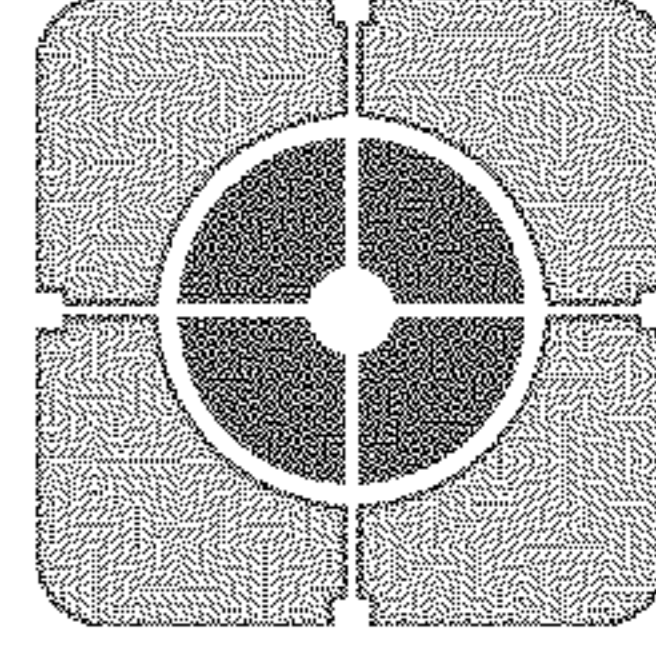

Peninsula Survey Group PTY LTD
Consulting Land Surveyors
 24A Progress Street, Mornington, VIC. 3931.
 Phone: 9787 2980 mail@peninsulasurvey.com.au
 ACN 067 077 614

FILE REF: 6241 / PS

SCALE 1: 125
 LENGTHS ARE IN METRES
 1.25 0 1.25 2.5 3.75 5

Digitally signed by: Alan Leslie Runtig (Peninsula Survey Group Pty Ltd),
 Surveyor's Plan Version (4.1),
 15/11/2016 Amended: 16/12/2016

Digitally signed by:
 Maribyrnong City Council,
 16/11/2016,
 SPEAR Ref: S085223M

SHEET 20

ORIGINAL SHEET SIZE: A3

PS 600696N

LOWER BASEMENT - WEST

M.G.A. 94 ZONE 55



SEE SHEET 20

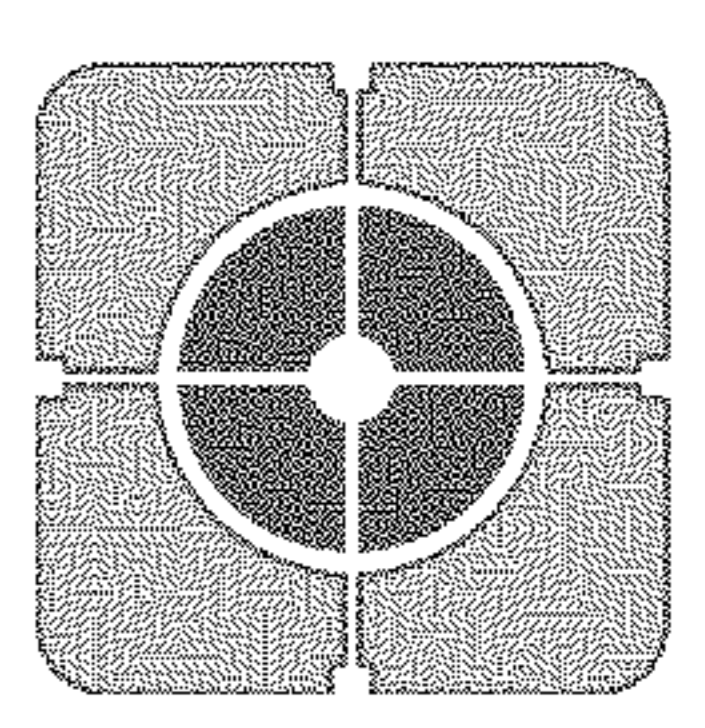
| | | | | | |
|--|---|-----------------|---|----------------------------|----------|
|  <p>Peninsula Survey Group PTY LTD Consulting Land Surveyors 24A Progress Street, Mornington, VIC. 3931. Phone: 9787 2980 mail@peninsulasurvey.com.au ACN 067 077 614</p> | FILE REF: 6241 / PS | SCALE 1: 125 | 1.25 0 1.25 2.5 3.75 5 LENGTHS ARE IN METRES | ORIGINAL SHEET SIZE: A3 | SHEET 21 |
| | Digitally signed by: Alan Leslie Runtling (Peninsula Survey Group Pty Ltd), Surveyor's Plan Version (4.1), 15/11/2016 Amended: 16/12/2016 | | Digitally signed by: Maribyrnong City Council, 16/11/2016, SPEAR Ref: S085223M | | |

BASEMENT - WEST
DIAGRAM 6

109°22'20" 54.32

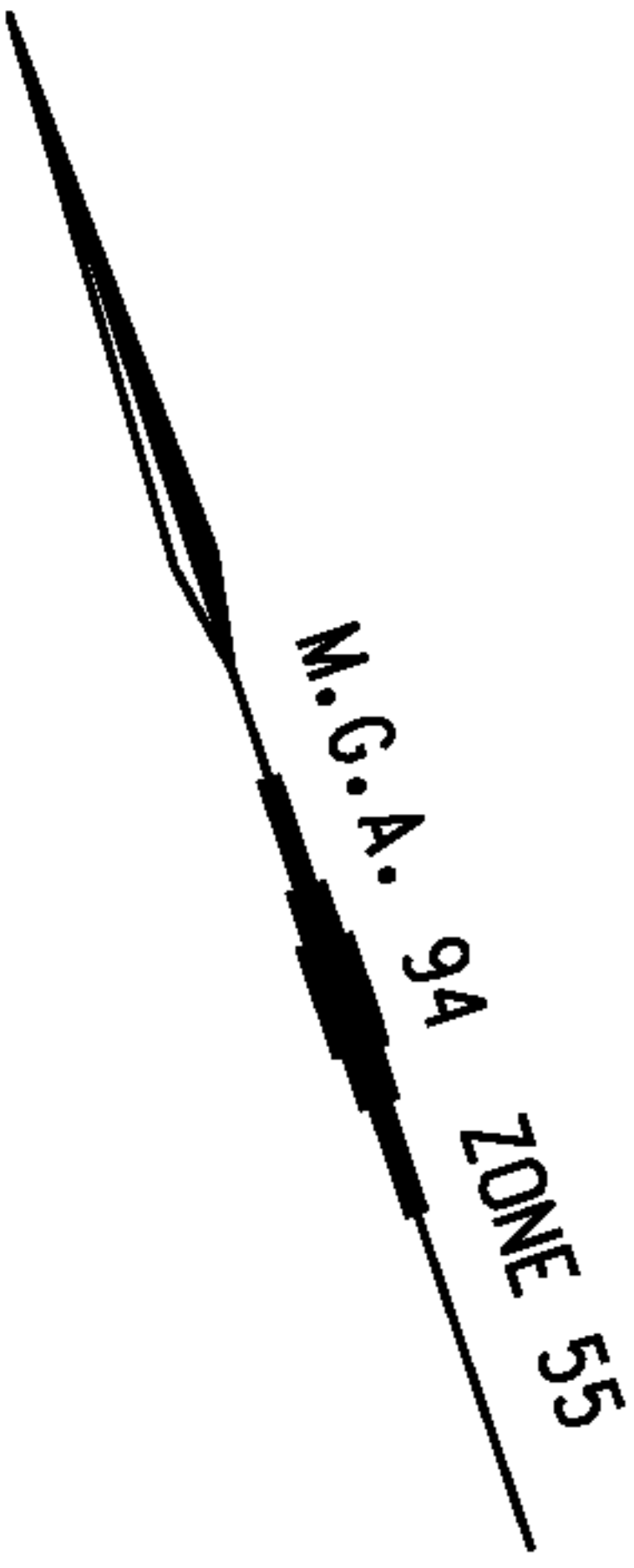

MORELAND STREET

18°40'20" 81.02

COMMON PROPERTY 3

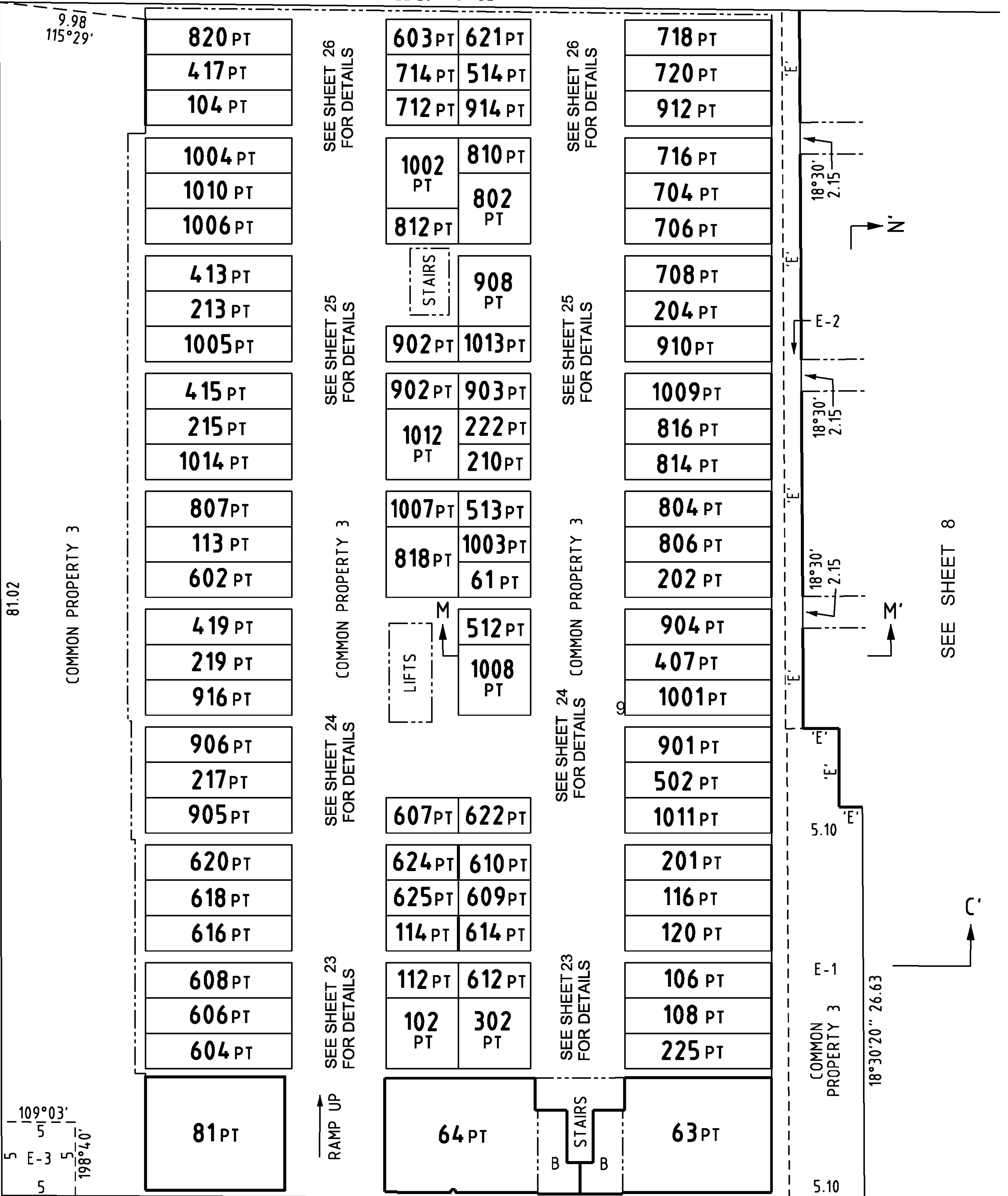

109°03' 58.56

SALTRIVER PLACE

109°03' 58.56

109°03' 58.56
E-3
198°40'

SEE SHEET 8

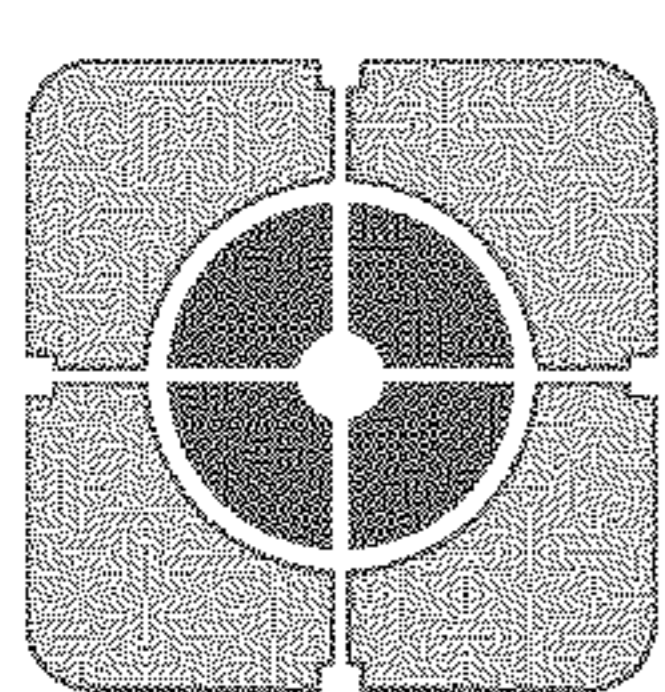

Peninsula Survey Group PTY LTD
Consulting Land Surveyors
24A Progress Street, Mornington, VIC. 3931.
Phone: 9787 2980 mail@peninsulasurvey.com.au
ACN 067 077 614

FILE REF: 6241 / PS

SCALE
1: 300



ORIGINAL
SHEET SIZE: A3

SHEET 22

Digitally signed by: Alan Leslie Runting (Peninsula Survey Group Pty Ltd),
Surveyor's Plan Version (4.1),
15/11/2016 Amended: 16/12/2016

Digitally signed by:
Maribyrnong City Council,
16/11/2016,
SPEAR Ref: S085223M

PS 600696N

BASEMENT - WEST

SEE SHEET 24

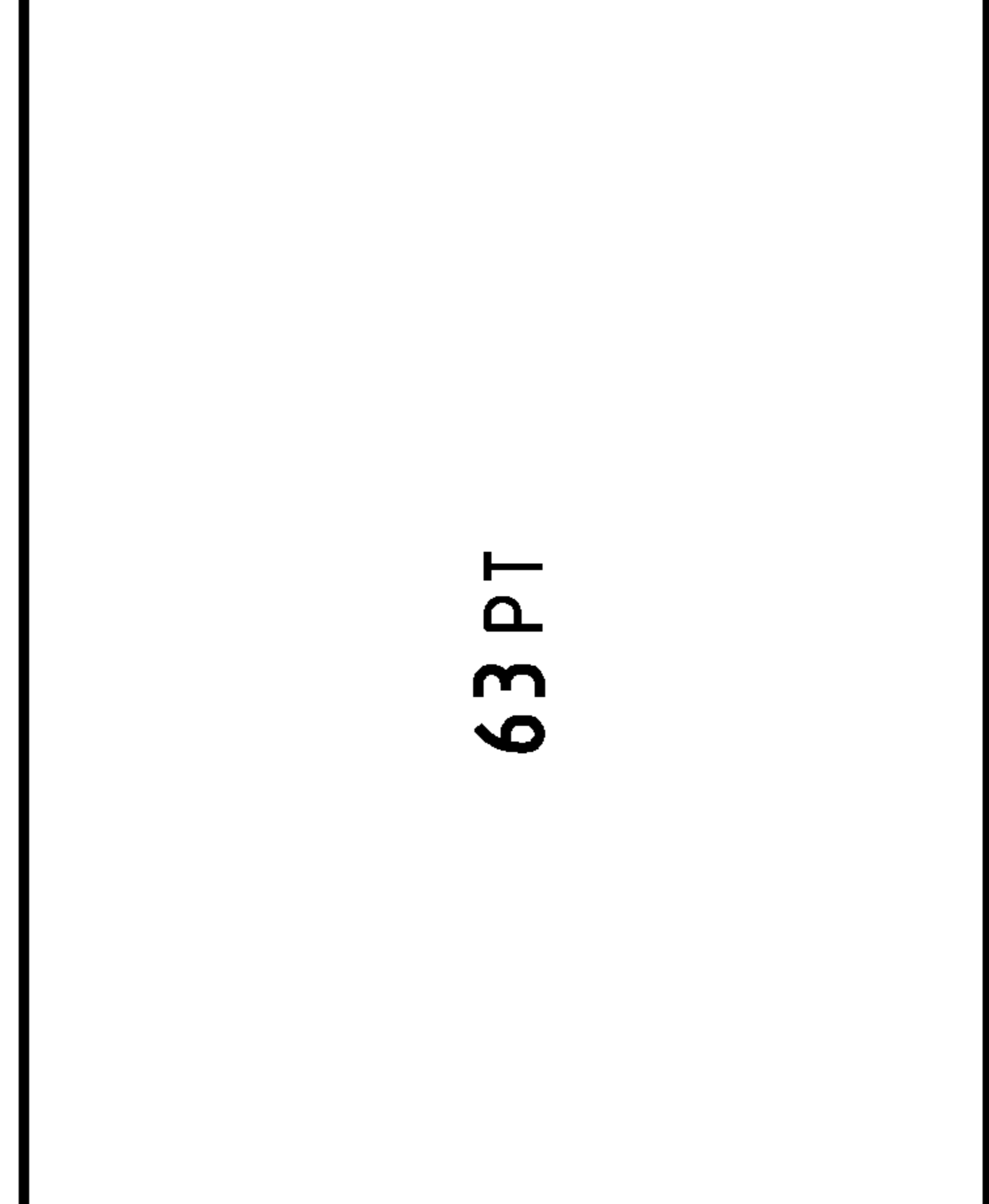
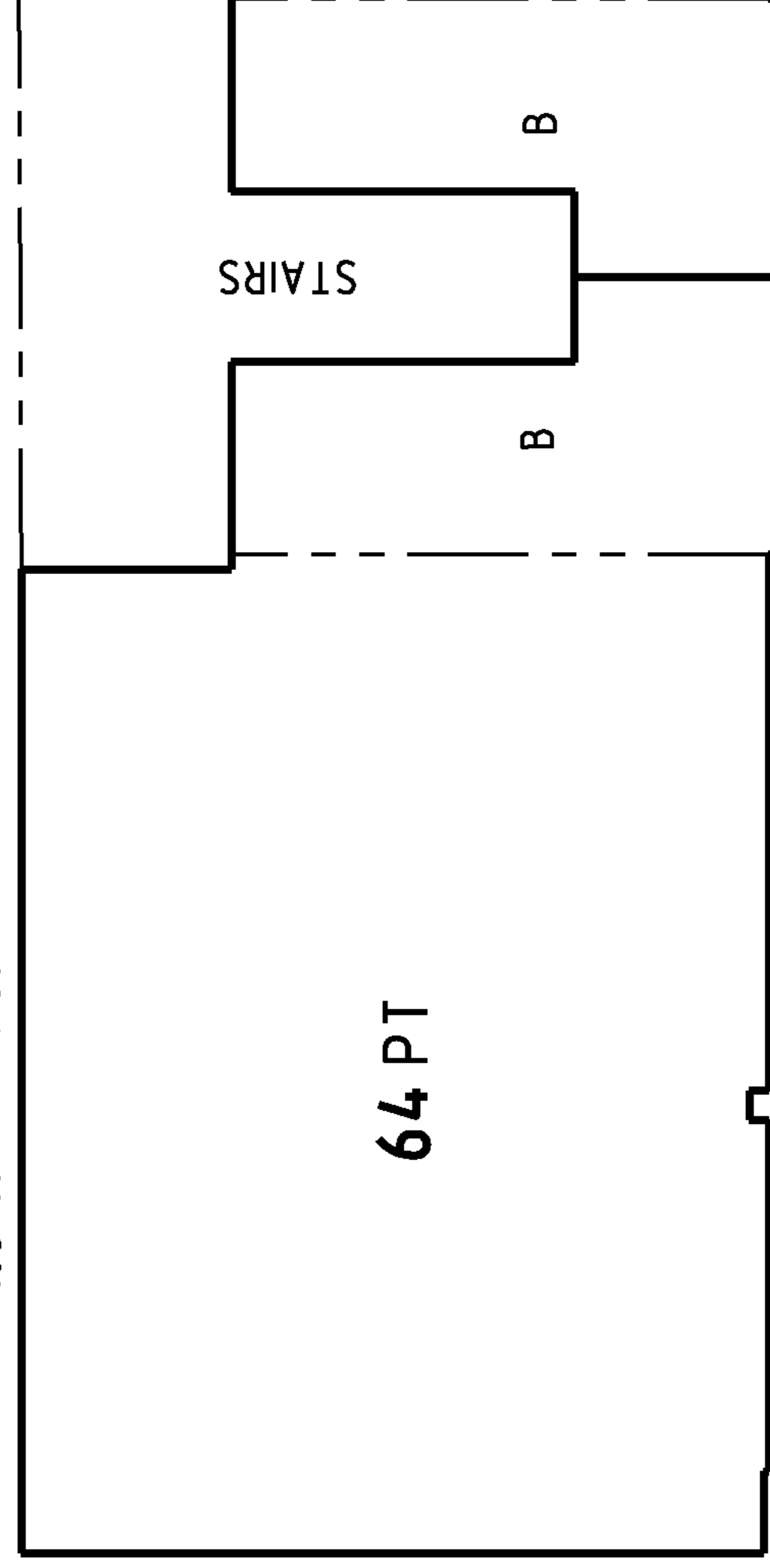
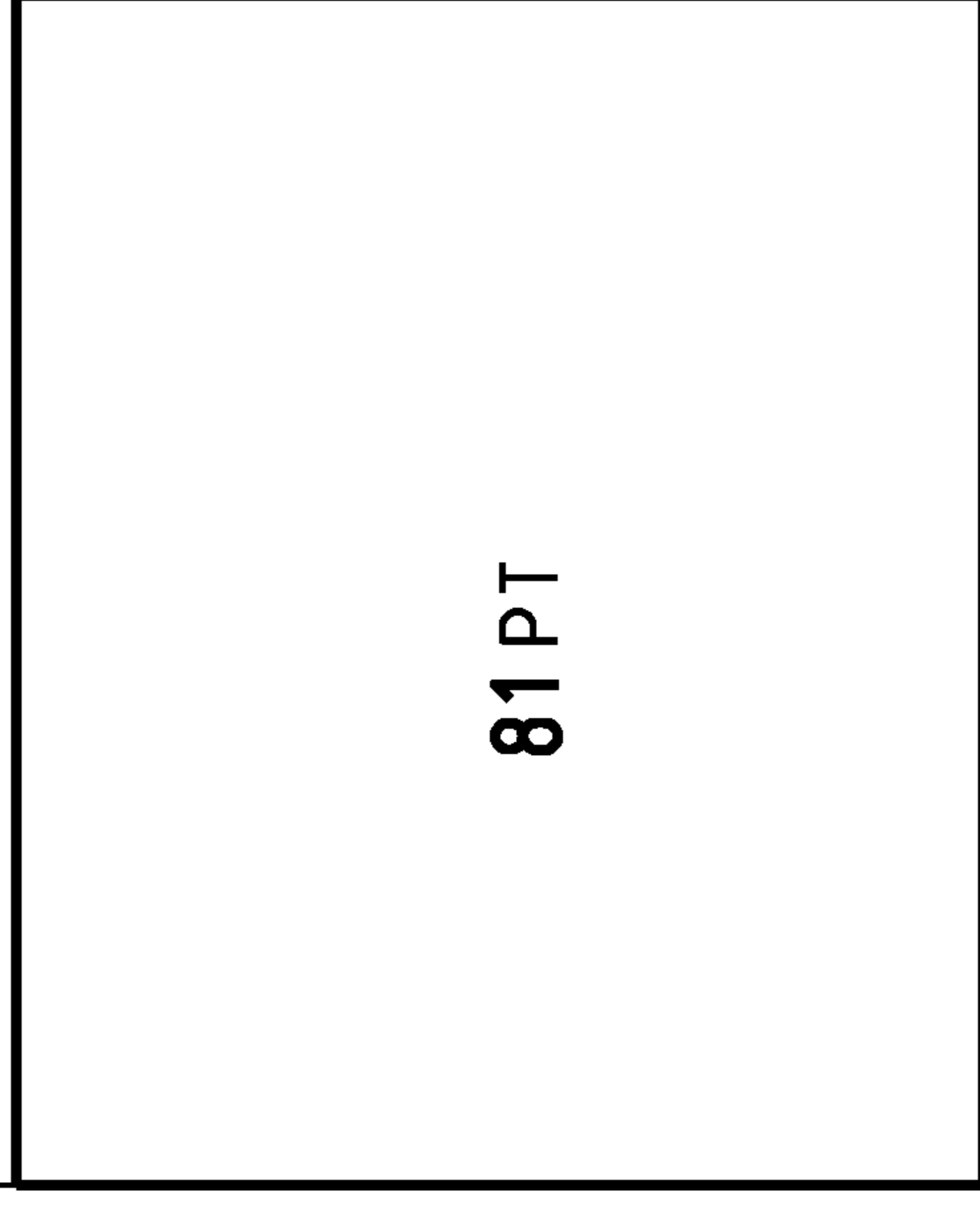
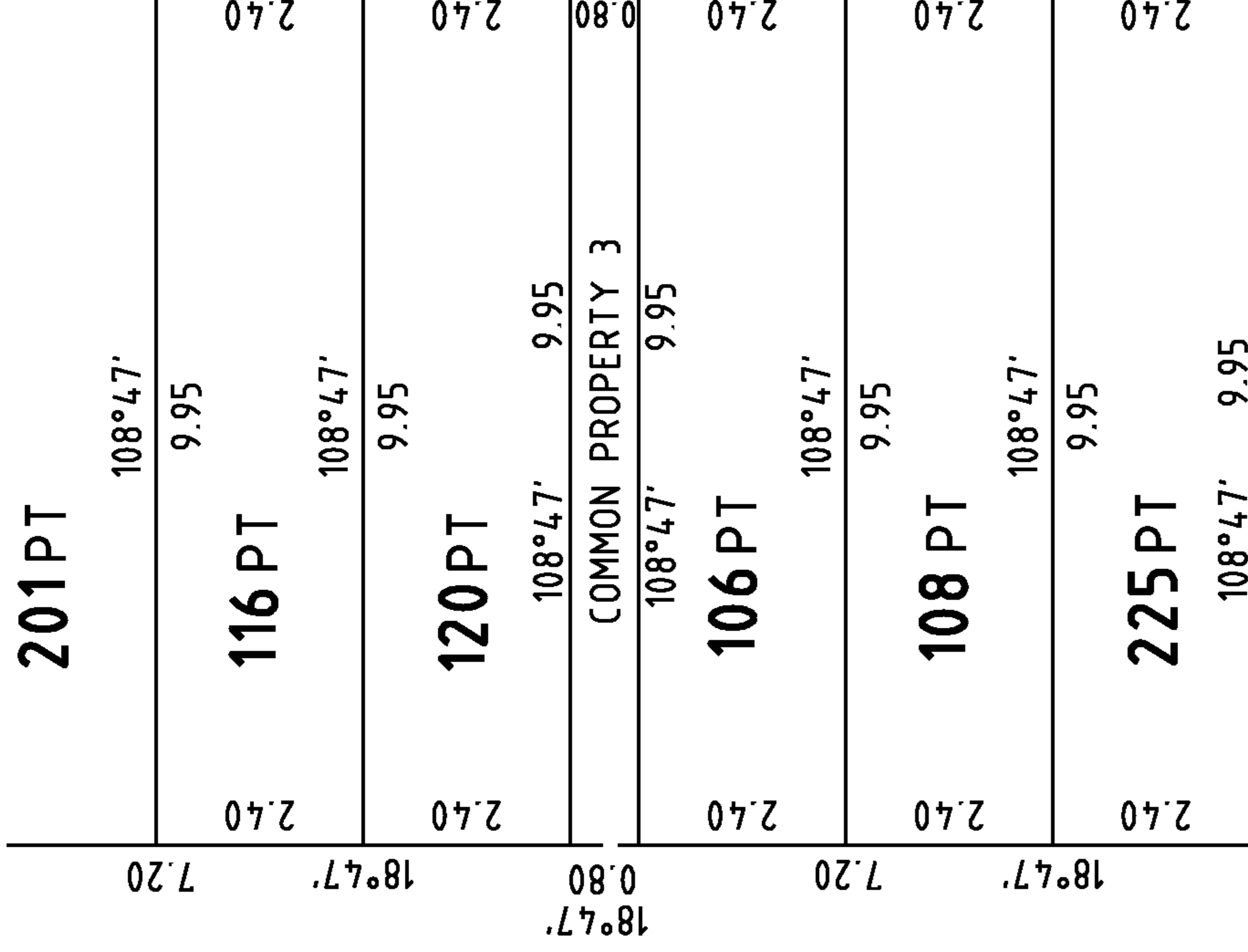
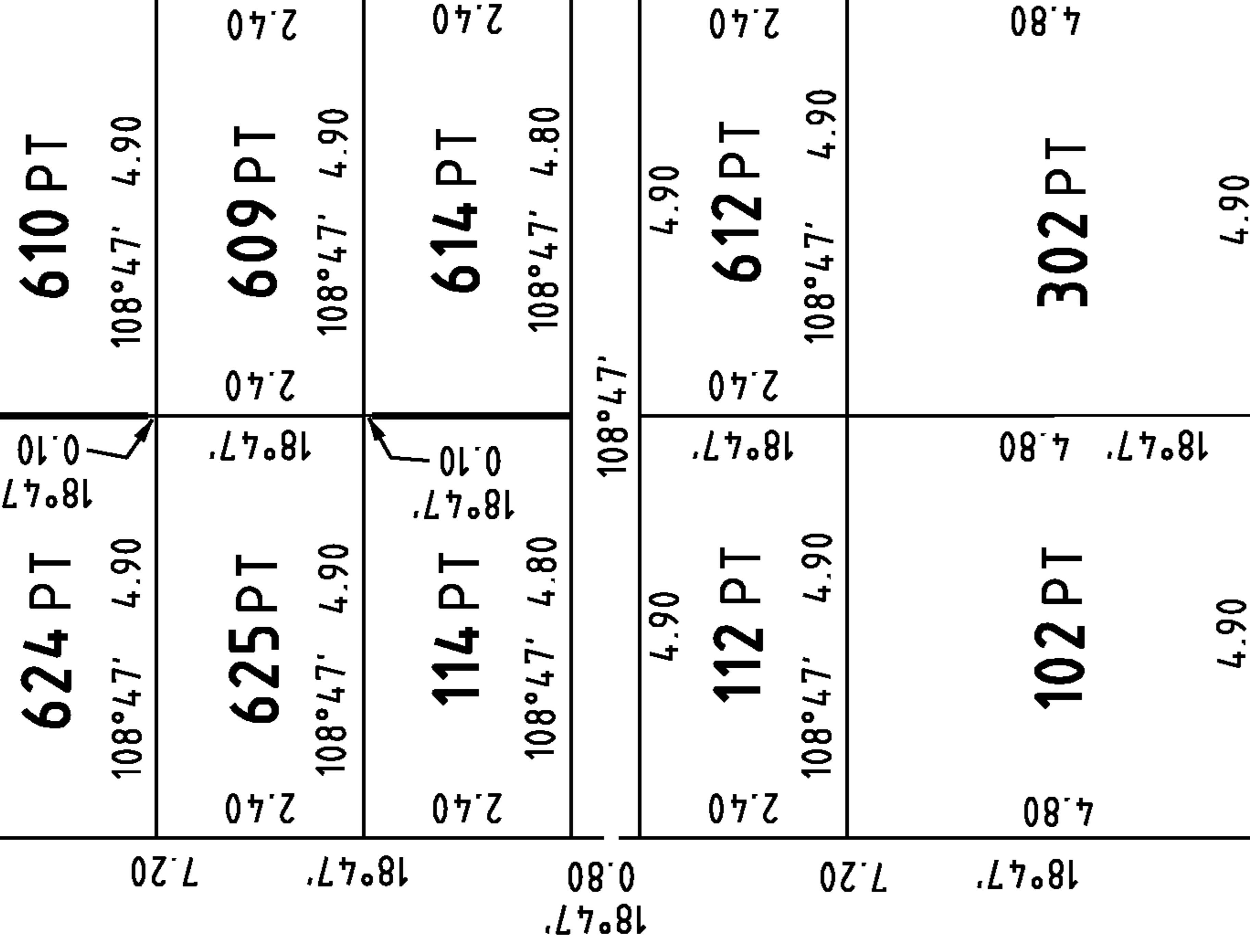
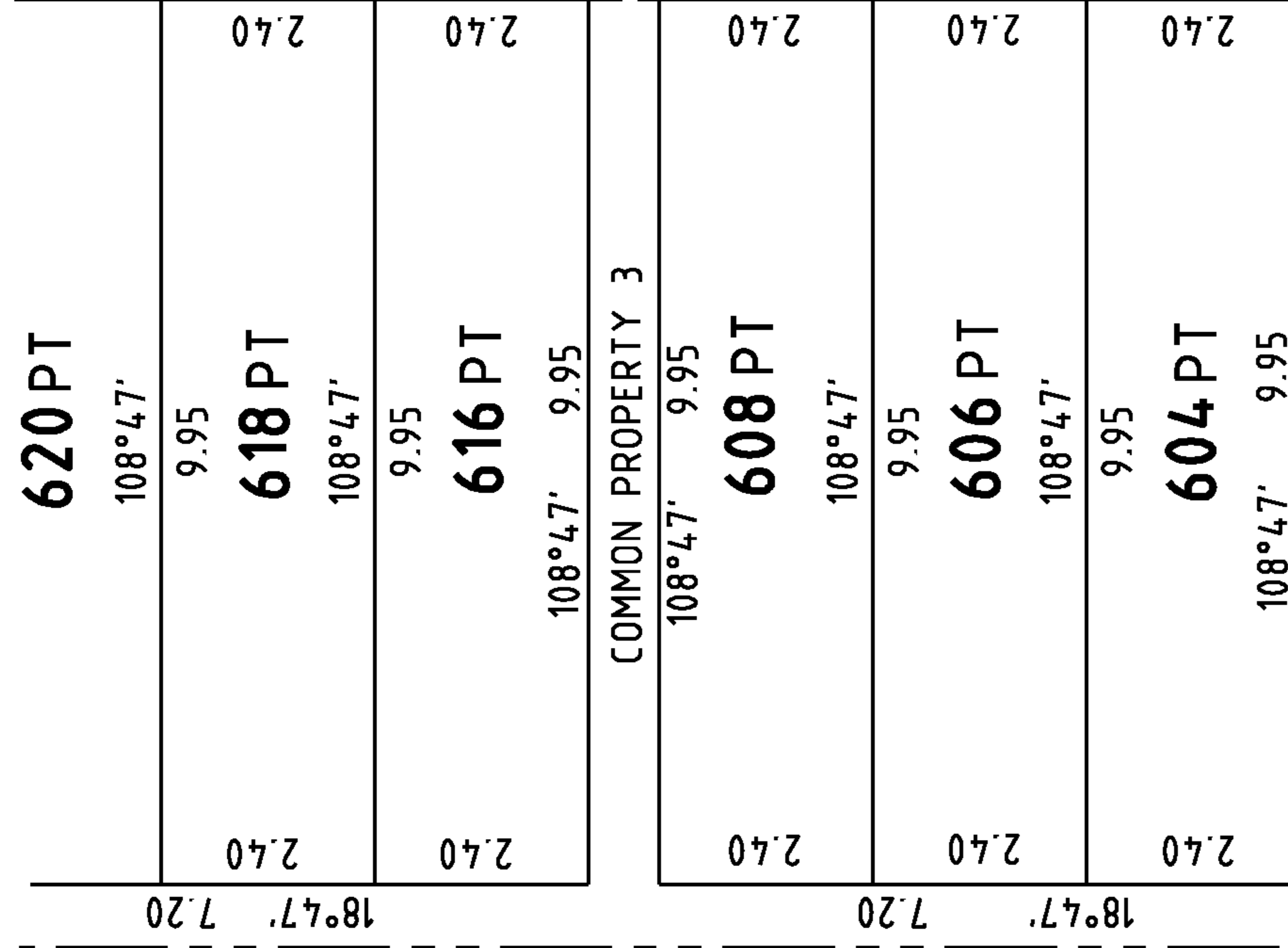

109°03' 58.56

SALTRIVER PLACE

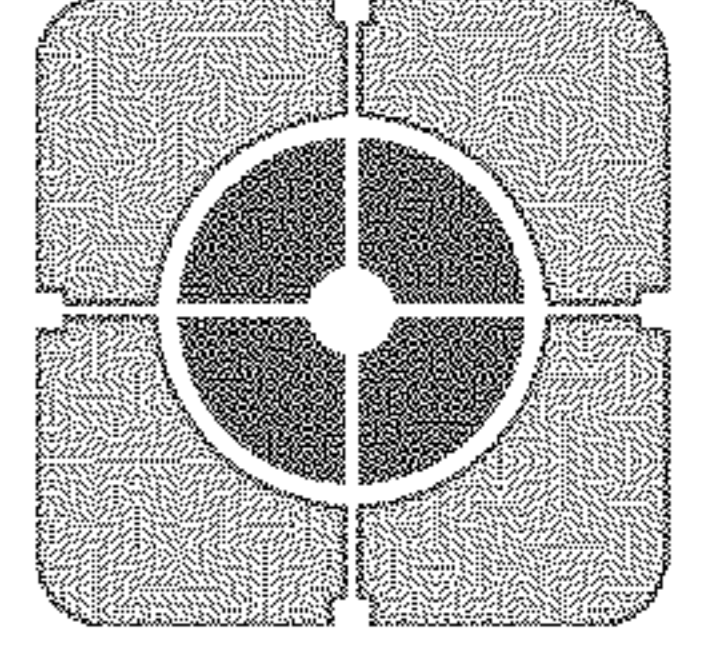

Peninsula Survey Group PTY LTD
Consulting Land Surveyors
 24A Progress Street, Mornington, VIC. 3931.
 Phone: 9787 2980 mail@peninsulasurvey.com.au
 ACN 067 077 614

FILE REF: 6241 / PS

SCALE 1: 125
 LENGTHS ARE IN METRES
 1.25 0 1.25 2.5 3.75 5

Digitally signed by: Alan Leslie Runtling (Peninsula Survey Group Pty Ltd),
 Surveyor's Plan Version (4.1),
 15/11/2016 Amended: 16/12/2016

Digitally signed by:
 Maribyrnong City Council,
 16/11/2016,
 SPEAR Ref: S085223M

SHEET 23

COMMON PROPERTY 3

COMMON PROPERTY 3

COMMON PROPERTY 3

COMMON PROPERTY 3

E-1

RAMP UP

STAIRS

M.C.A. 94 ZONE 55

PS 600696N

BASEMENT - WEST

SEE SHEET 25

M.G.A. 64 ZONE 55

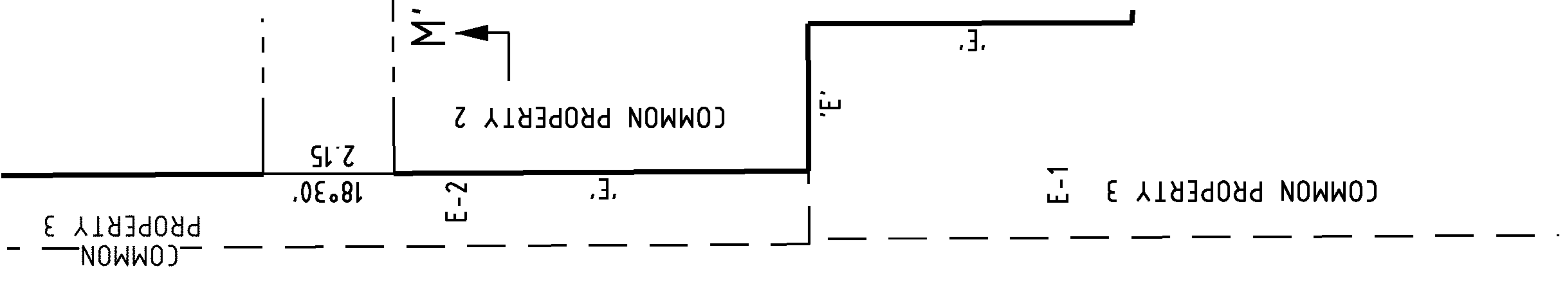
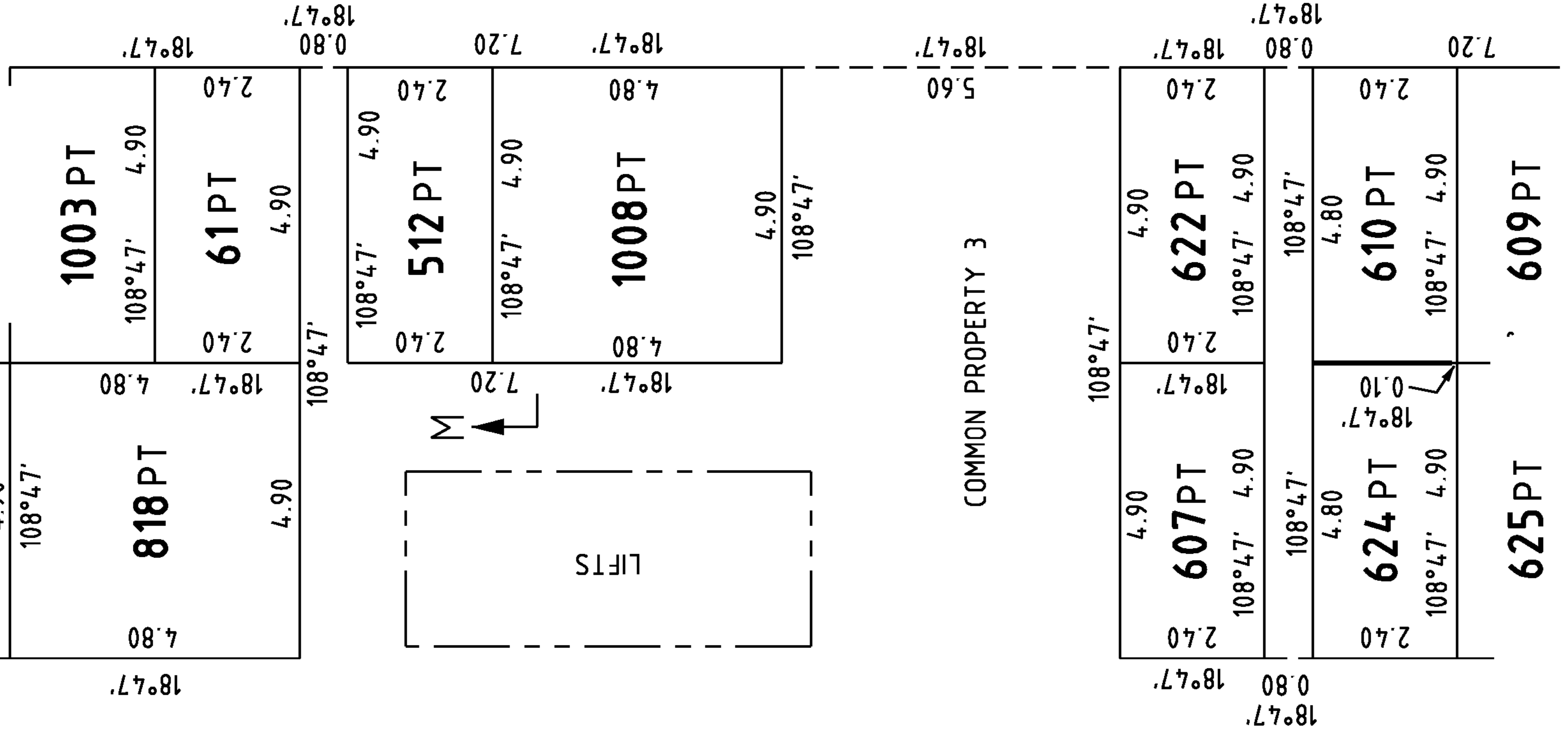
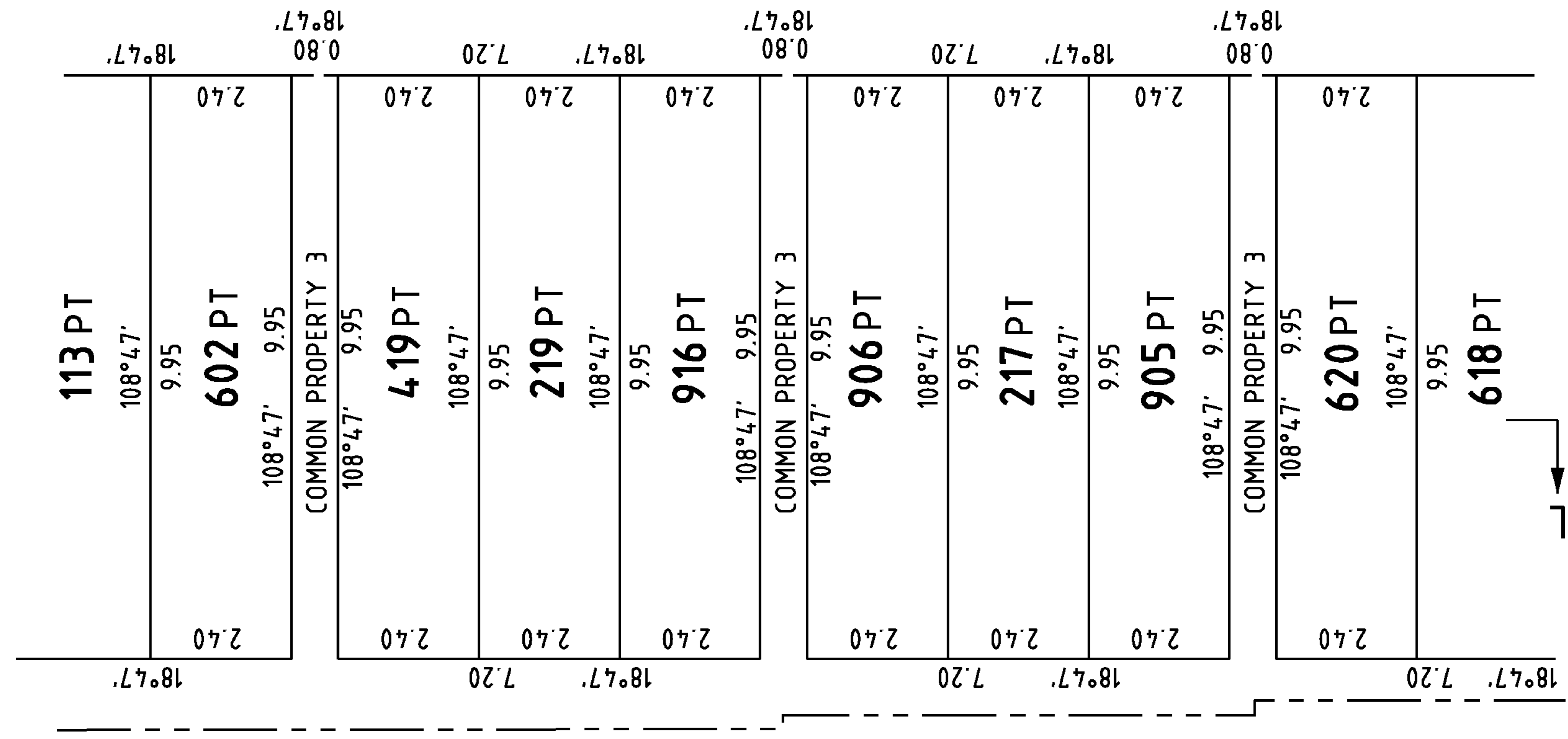

SEE SHEET 23

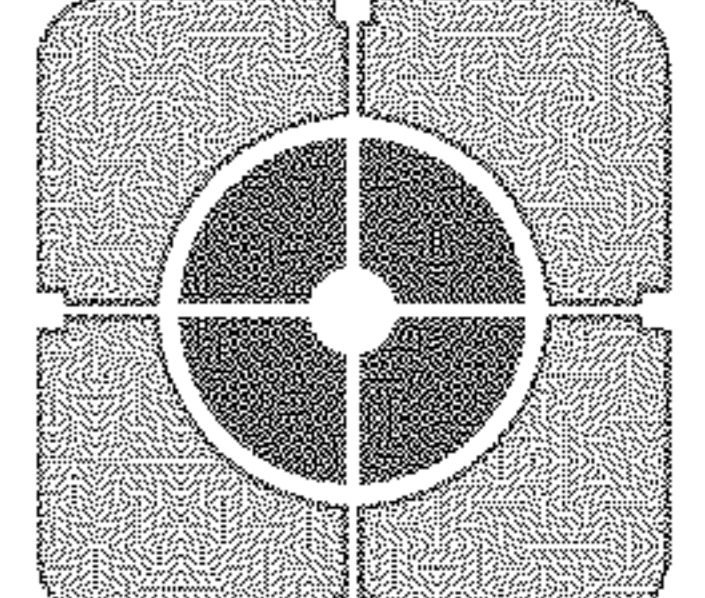

Peninsula Survey Group PTY LTD
Consulting Land Surveyors
 24A Progress Street, Mornington, VIC. 3931.
 Phone: 9787 2980 mail@peninsulasurvey.com.au
 ACN 067 077 614

FILE REF: 6241 / PS

SCALE 1: 125
 LENGTHS ARE IN METRES
 1.25 0 1.25 2.5 3.75 5

Digitally signed by: Alan Leslie Runtig (Peninsula Survey Group Pty Ltd),
 Surveyor's Plan Version (4.1),
 15/11/2016 Amended: 16/12/2016

Digitally signed by:
 Maribyrnong City Council,
 16/11/2016,
 SPEAR Ref: S085223M

ORIGINAL SHEET SIZE: A3

SHEET 24

PS 600696N

BASEMENT - WEST

SEE SHEET 26


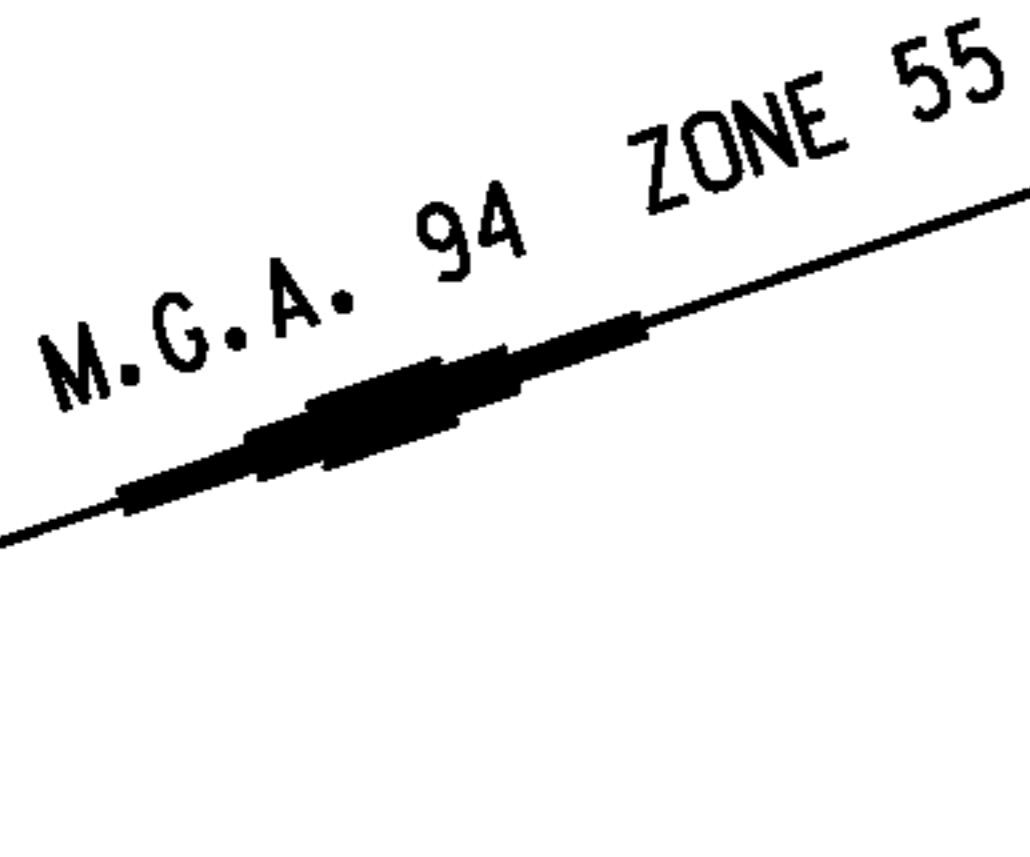

SEE SHEET 24

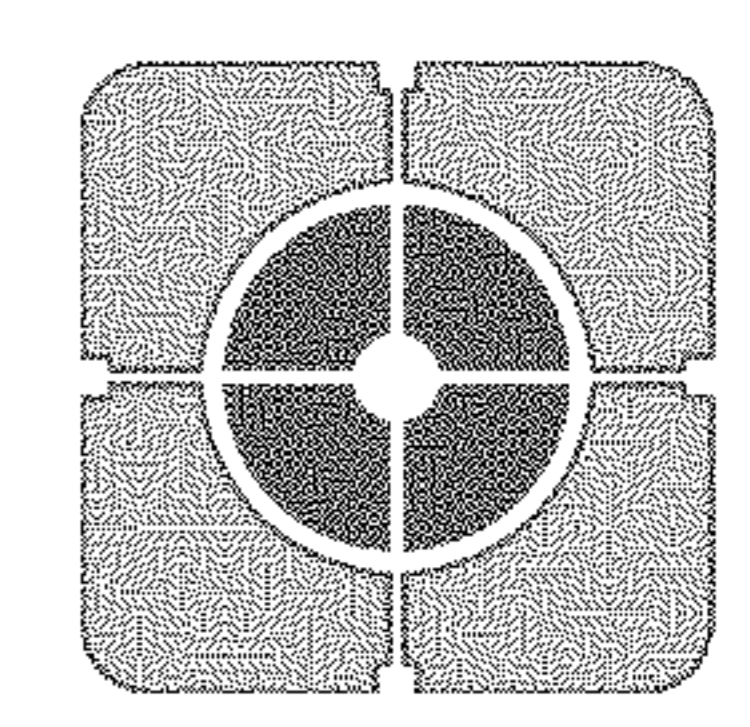

Peninsula Survey Group PTY LTD
Consulting Land Surveyors
 24A Progress Street, Mornington, VIC. 3931.
 Phone: 9787 2980 mail@peninsulasurvey.com.au
 ACN 067 077 614

FILE REF: 6241 / PS

SCALE
 1: 125

1.25 0 1.25 2.5 3.75 5
 LENGTHS ARE IN METRES

ORIGINAL SHEET
 SIZE: A3

SHEET 25

Digitally signed by: Alan Leslie Runtig (Peninsula Survey Group Pty Ltd),
 Surveyor's Plan Version (4.1),
 15/11/2016 Amended: 16/12/2016

Digitally signed by:
 Maribyrnong City Council,
 16/11/2016,
 SPEAR Ref: S085223M

PS 600696N

BASEMENT - WEST

M.G.A. 94 ZONE 55



SEE SHEET 25

| | | | | | |
|---|----------------------------|-------------------------|---|------------------------------------|-----------------|
|  <p>Peninsula Survey Group PTY LTD Consulting Land Surveyors 24A Progress Street, Mornington, VIC. 3931. Phone: 9787 2980 mail@peninsulasurvey.com.au ACN 067 077 614</p> | <p>FILE REF: 6241 / PS</p> | <p>SCALE 1: 125</p> | <p>1.25 0 1.25 2.5 3.75 5 LENGTHS ARE IN METRES</p> | <p>ORIGINAL SHEET SIZE: A3</p> | <p>SHEET 26</p> |
| <p>Digitally signed by: Alan Leslie Runtling (Peninsula Survey Group Pty Ltd), Surveyor's Plan Version (4.1), 15/11/2016 Amended: 16/12/2016</p> | | | | | |
| <p>Digitally signed by: Maribyrnong City Council, 16/11/2016, SPEAR Ref: S085223M</p> | | | | | |

LEVEL 1-WEST

SEE SHEET 28

COMMON PROPERTY 3

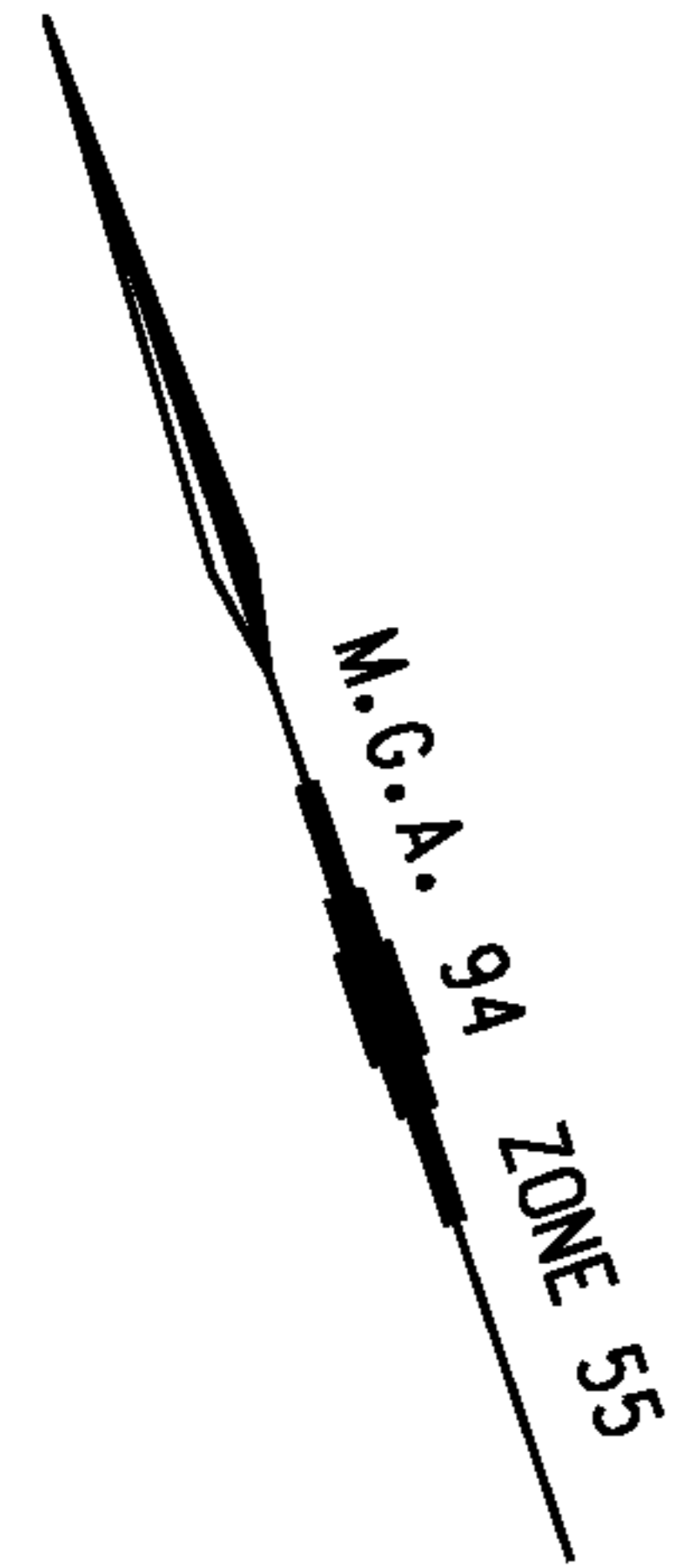

MORELAND STREET



SEE SHEET 16

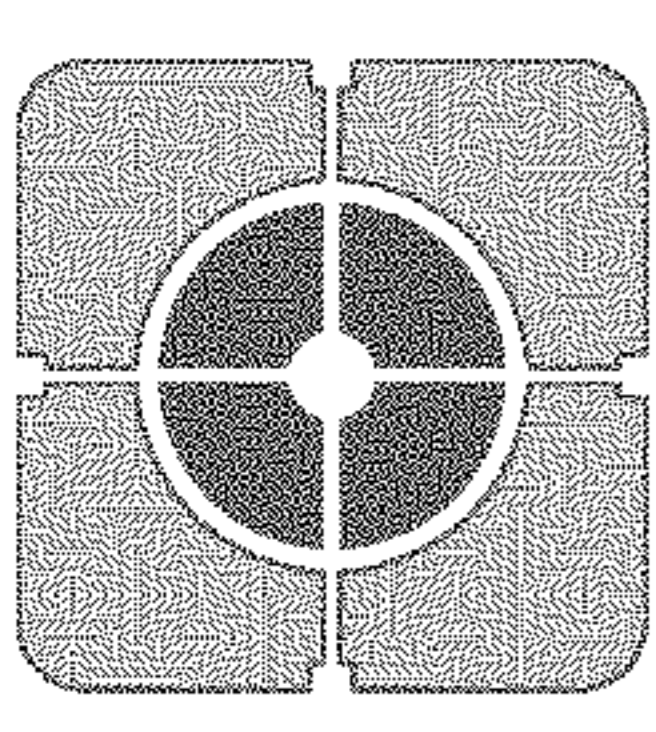

Peninsula Survey Group PTY LTD
 Consulting Land Surveyors
 24A Progress Street, Mornington, VIC. 3931.
 Phone: 9787 2980 mail@peninsulasurvey.com.au
 ACN 067 077 614

FILE REF: 6241 / PS

SCALE
 1: 125

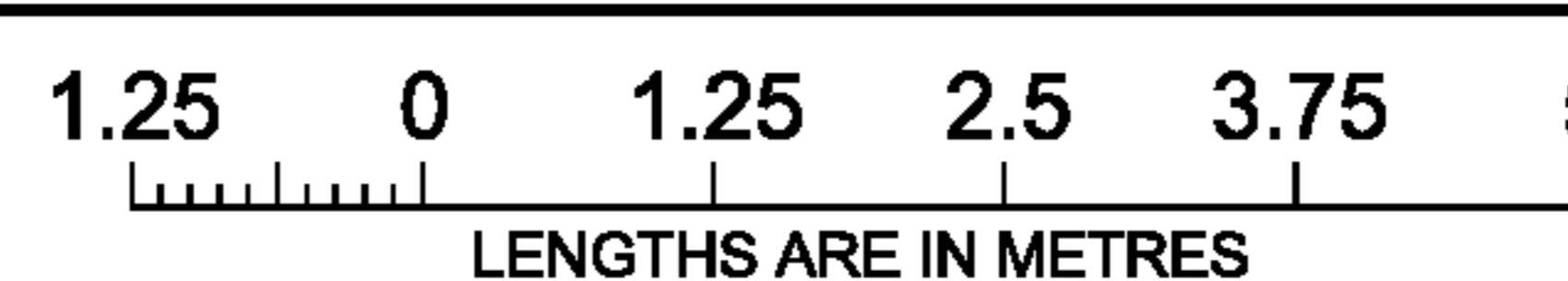

ORIGINAL SHEET SIZE: A3

SHEET 27

Digitally signed by: Alan Leslie Runting (Peninsula Survey Group Pty Ltd),
 Surveyor's Plan Version (4.1),
 15/11/2016 Amended: 16/12/2016

Digitally signed by:
 Maribyrnong City Council,
 16/11/2016,
 SPEAR Ref: S085223M

LEVEL 2-WEST
DIAGRAM 7

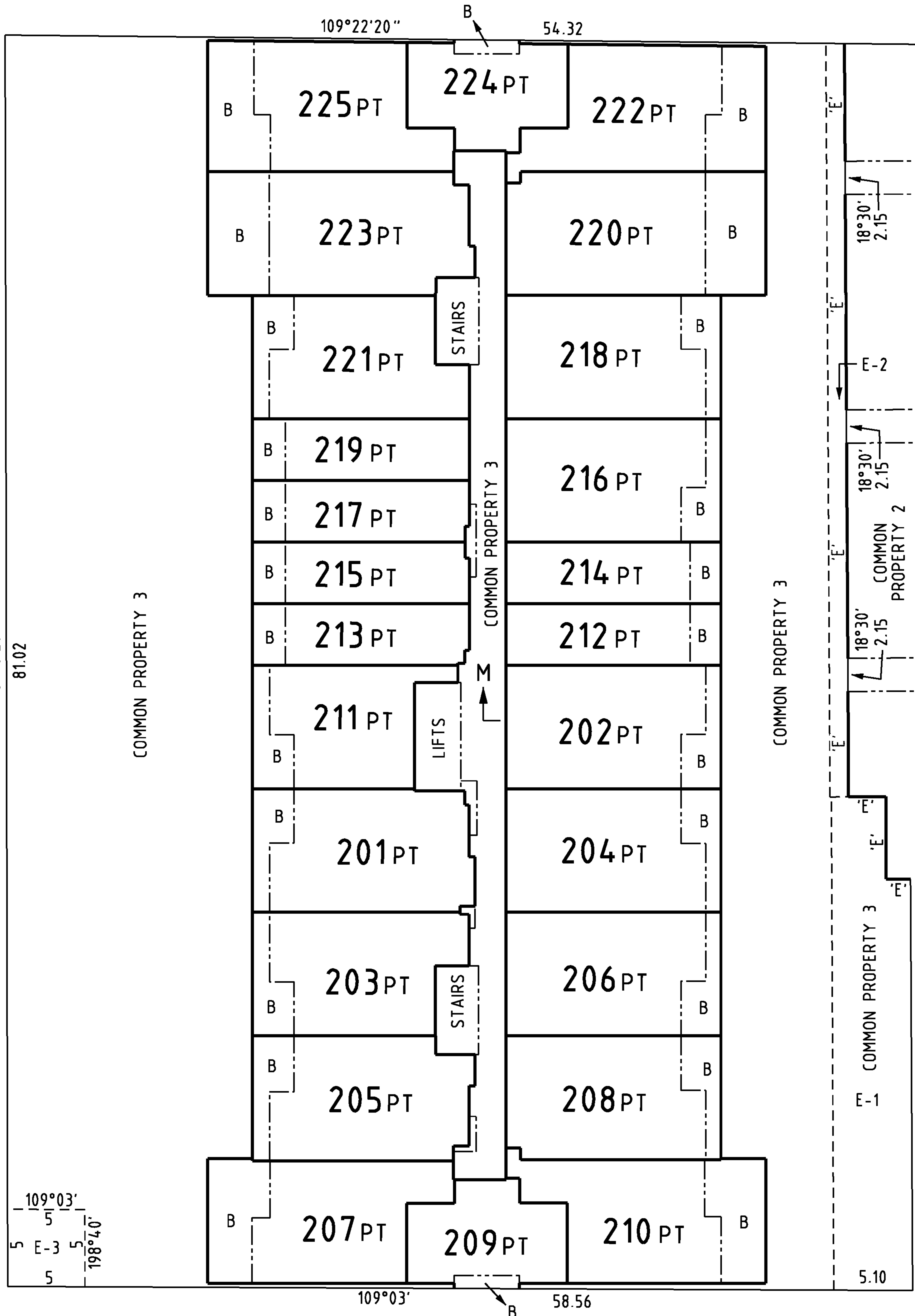

SEE SHEET 8

MORELAND STREET

SALTRIVER PLACE

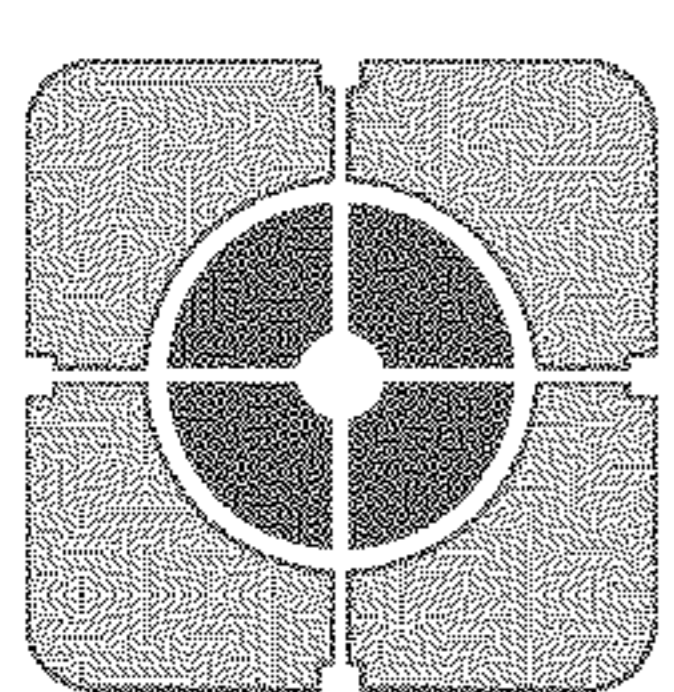

Peninsula Survey Group PTY LTD
Consulting Land Surveyors
24A Progress Street, Mornington, VIC. 3931.
Phone: 9787 2980 mail@peninsulasurvey.com.au
ACN 067 077 614

FILE REF: 6241 / PS

SCALE
1: 300



ORIGINAL
SHEET SIZE: A3

SHEET 29

Digitally signed by: Alan Leslie Runting (Peninsula Survey Group Pty Ltd),
Surveyor's Plan Version (4.1),
15/11/2016 Amended: 16/12/2016

Digitally signed by:
Maribyrnong City Council,
16/11/2016,
SPEAR Ref: S085223M

LEVEL 3-WEST

DIAGRAM 8

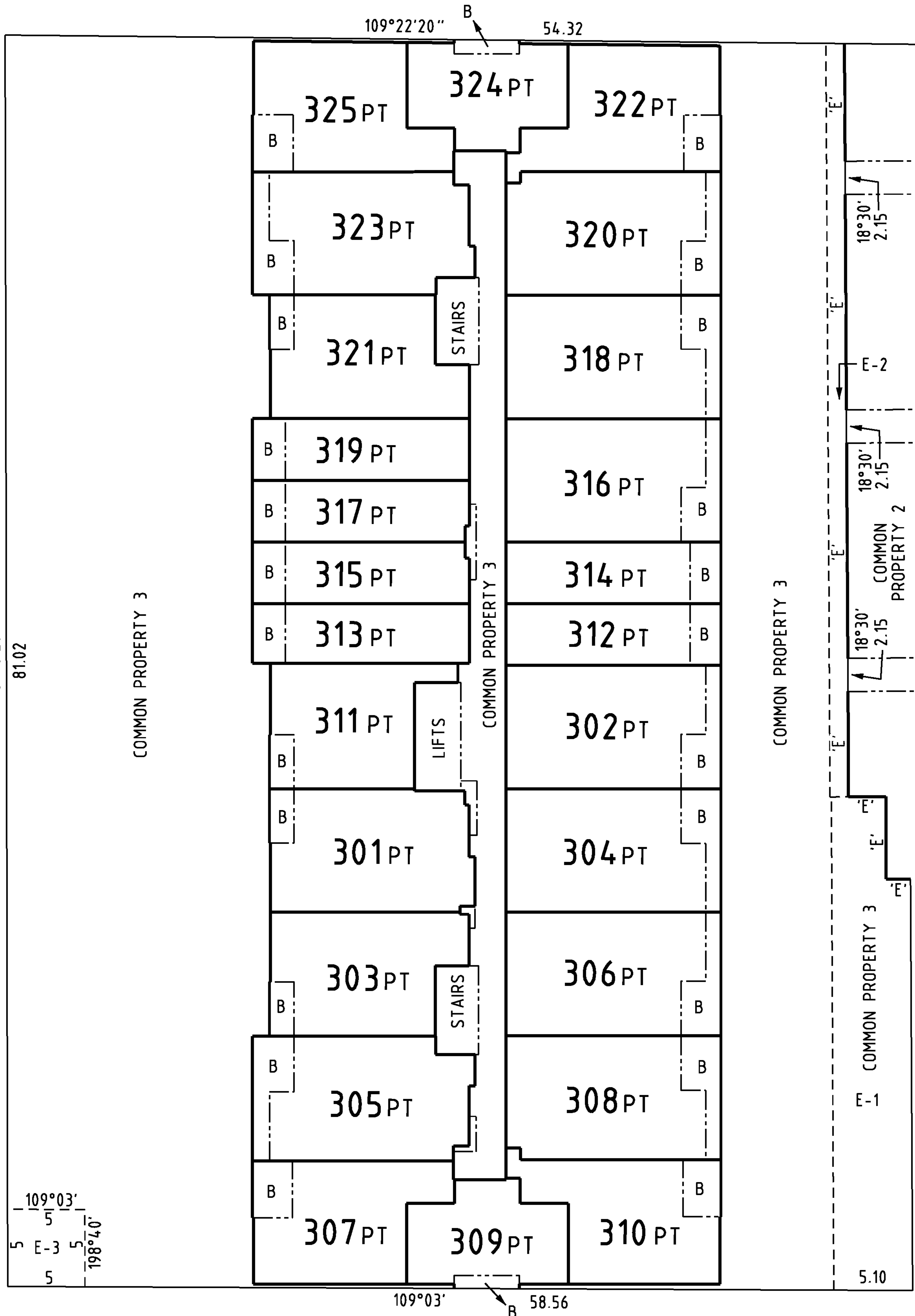
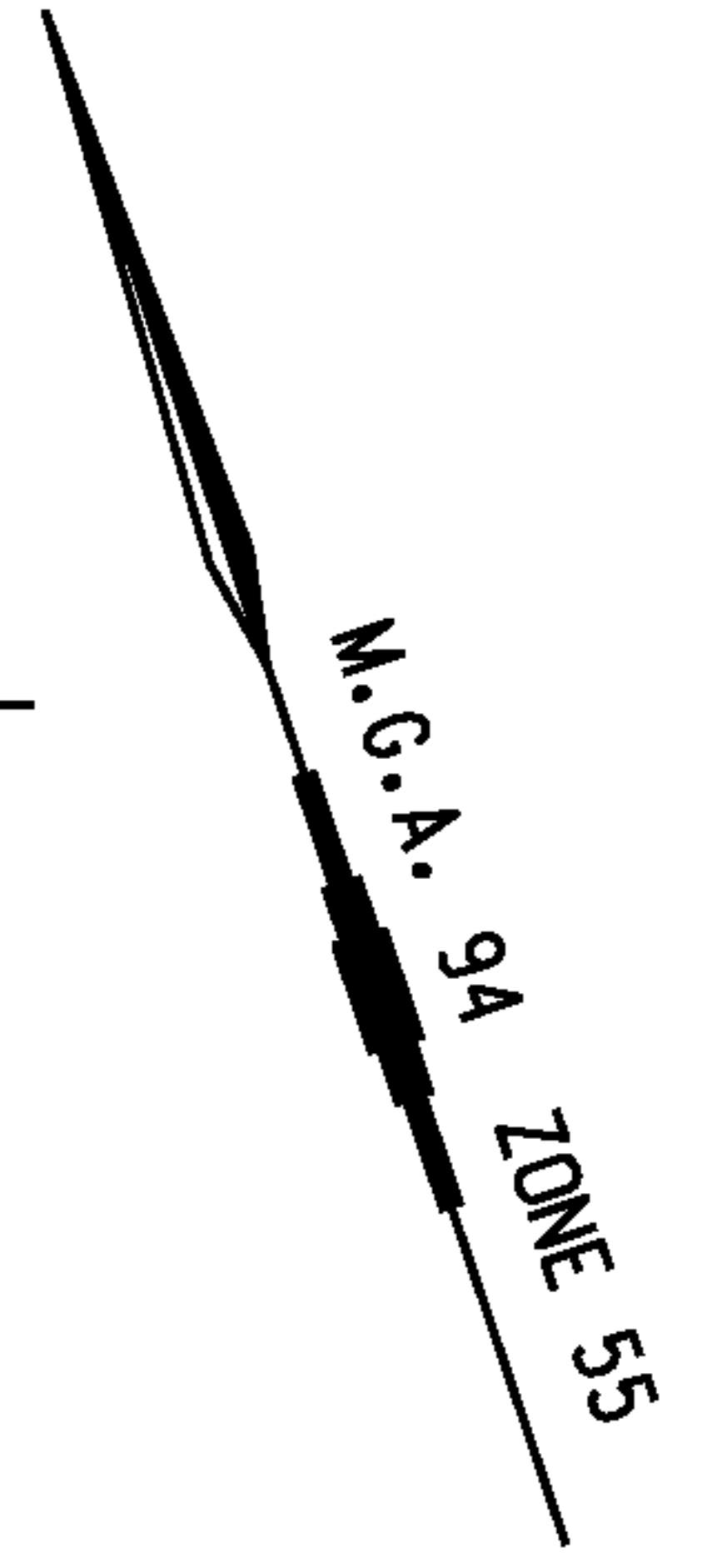

MORELAND STREET

SALTRIVER PLACE

SEE SHEET 8

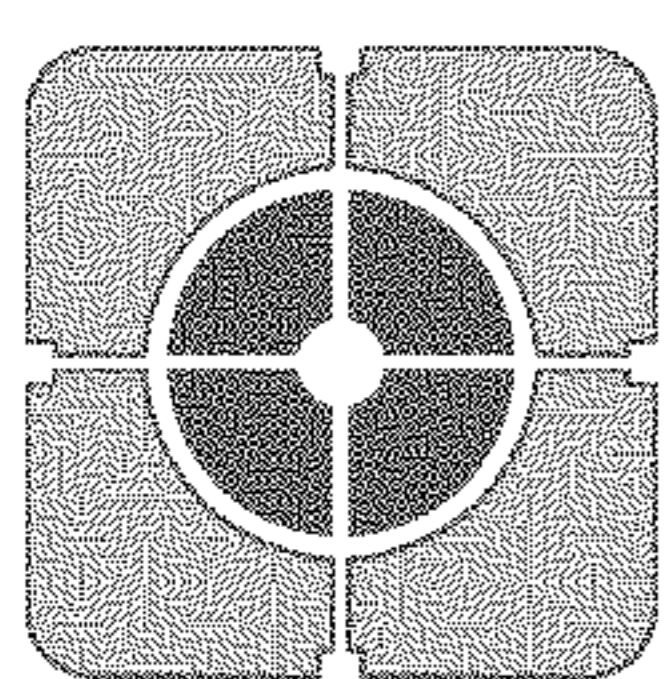

Peninsula Survey Group PTY LTD
 Consulting Land Surveyors
 24A Progress Street, Mornington, VIC. 3931.
 Phone: 9787 2980 mail@peninsulasurvey.com.au
 ACN 067 077 614

FILE REF: 6241 / PS

SCALE
 1: 300



ORIGINAL SHEET SIZE: A3

SHEET 30

Digitally signed by: Alan Leslie Runting (Peninsula Survey Group Pty Ltd),
 Surveyor's Plan Version (4.1),
 15/11/2016 Amended: 16/12/2016

Digitally signed by:
 Maribyrnong City Council,
 16/11/2016,
 SPEAR Ref: S085223M

LEVEL 4-WEST

DIAGRAM 9

M.G.A. 94
ZONE 55



MORELAND STREET

SALTRIVER PLACE

SEE SHEET 8

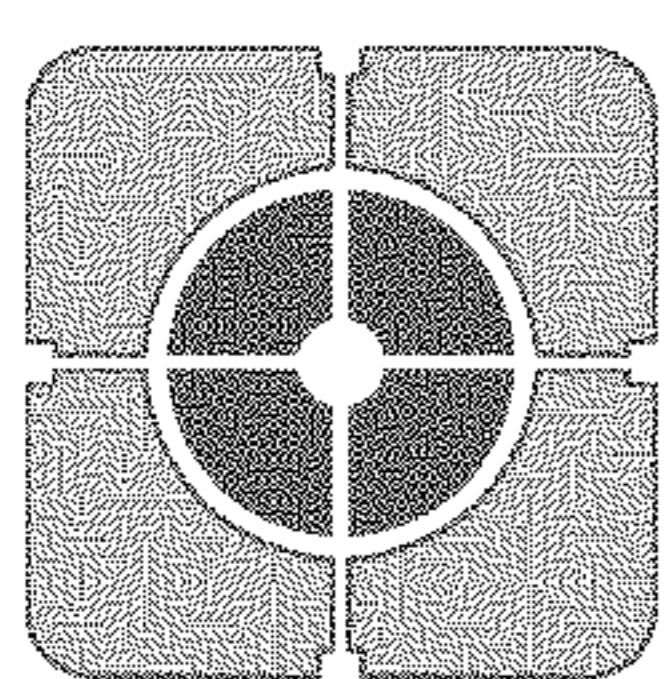

Peninsula Survey Group PTY LTD
 Consulting Land Surveyors
 24A Progress Street, Mornington, VIC. 3931.
 Phone: 9787 2980 mail@peninsulasurvey.com.au
 ACN 067 077 614

FILE REF: 6241 / PS

SCALE
1: 300



ORIGINAL SHEET SIZE: A3

SHEET 31

Digitally signed by: Alan Leslie Runting (Peninsula Survey Group Pty Ltd),
 Surveyor's Plan Version (4.1),
 15/11/2016 Amended: 16/12/2016

Digitally signed by:
 Maribyrnong City Council,
 16/11/2016,
 SPEAR Ref: S085223M

LEVEL 5-WEST

DIAGRAM 10

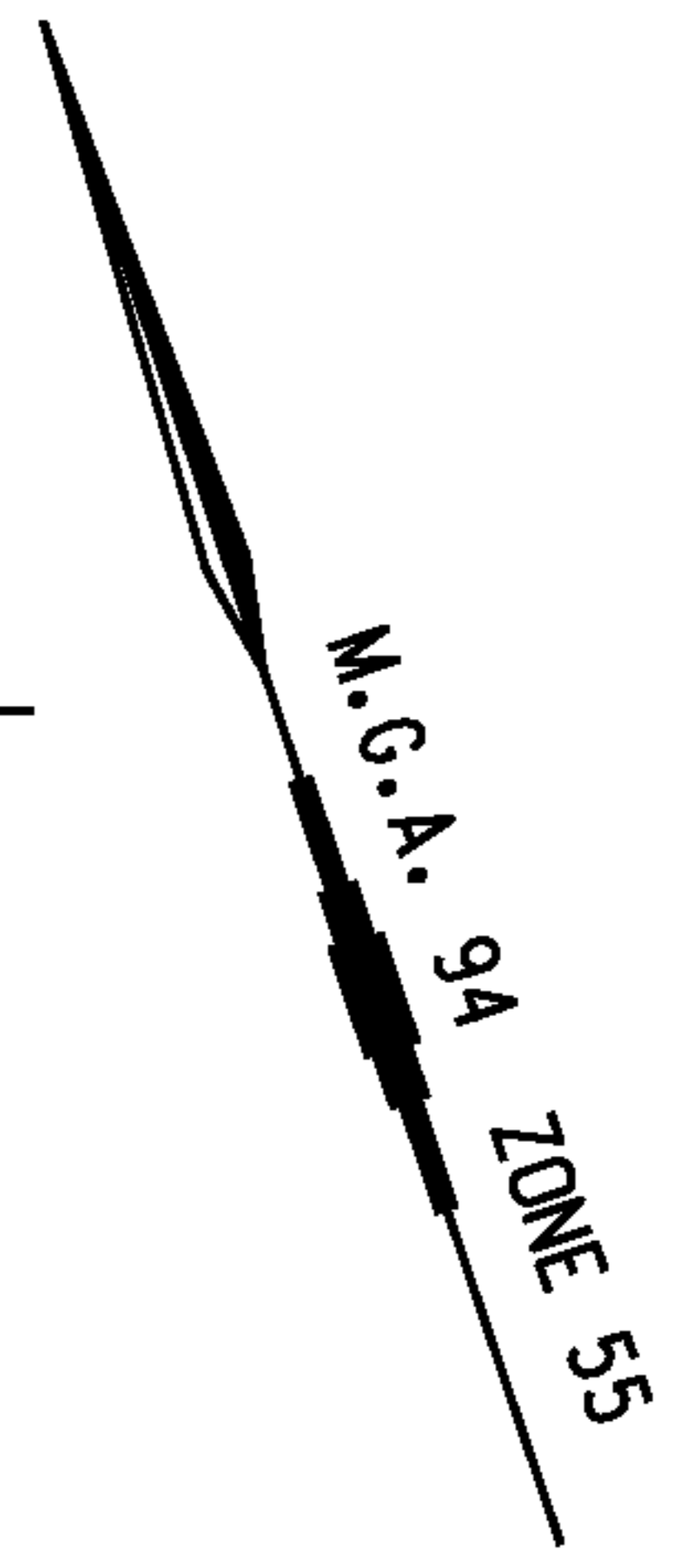

SEE SHEET 8

MORELAND STREET

SALTRIVER PLACE

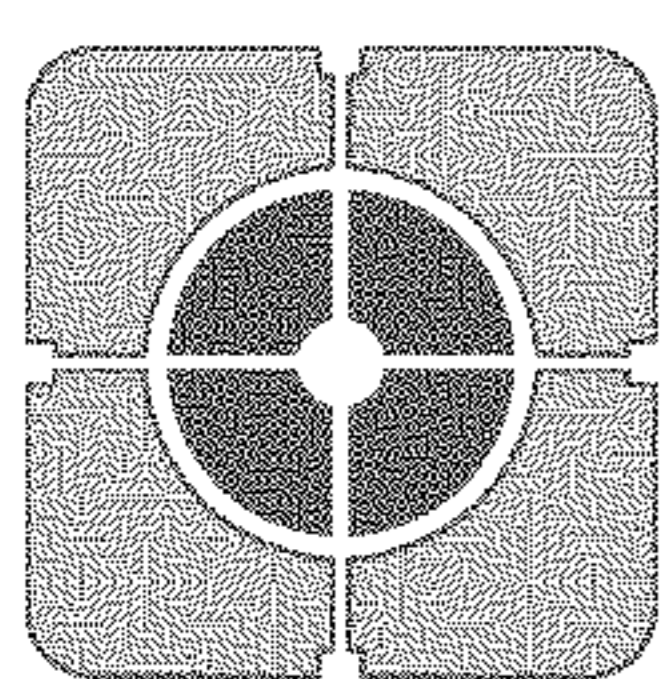

Peninsula Survey Group PTY LTD
 Consulting Land Surveyors
 24A Progress Street, Mornington, VIC. 3931.
 Phone: 9787 2980 mail@peninsulasurvey.com.au
 ACN 067 077 614

FILE REF: 6241 / PS

SCALE
 1: 300



ORIGINAL
 SHEET SIZE: A3

SHEET 32

Digitally signed by: Alan Leslie Runting (Peninsula Survey Group Pty Ltd),
 Surveyor's Plan Version (4.1),
 15/11/2016 Amended: 16/12/2016

Digitally signed by:
 Maribyrnong City Council,
 16/11/2016,
 SPEAR Ref: S085223M

LEVEL 6-WEST
DIAGRAM 11



SEE SHEET 8

MORELAND STREET

SALTRIVER PLACE

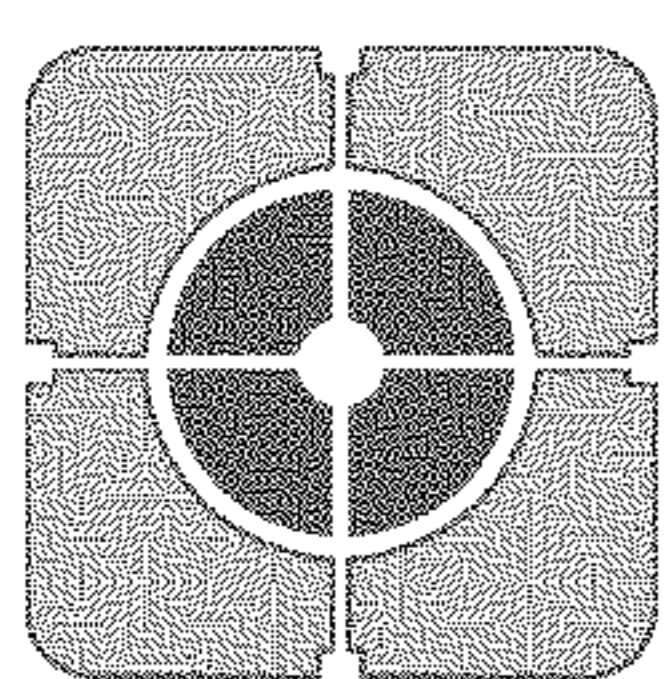

Peninsula Survey Group PTY LTD
 Consulting Land Surveyors
 24A Progress Street, Mornington, VIC. 3931.
 Phone: 9787 2980 mail@peninsulasurvey.com.au
 ACN 067 077 614

FILE REF: 6241 / PS

SCALE
1: 300

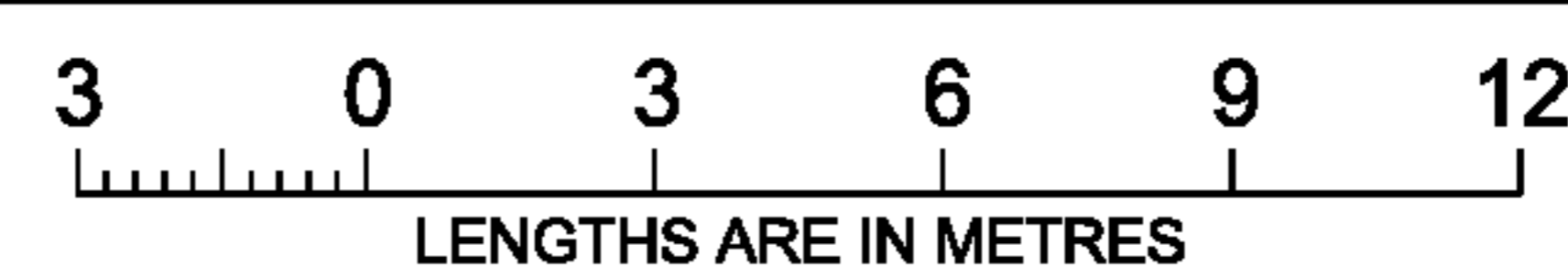

ORIGINAL SHEET SIZE: A3

SHEET 33

Digitally signed by: Alan Leslie Runting (Peninsula Survey Group Pty Ltd),
 Surveyor's Plan Version (4.1),
 15/11/2016 Amended: 16/12/2016

Digitally signed by:
 Maribyrnong City Council,
 16/11/2016,
 SPEAR Ref: S085223M

LEVEL 7-WEST
DIAGRAM 12

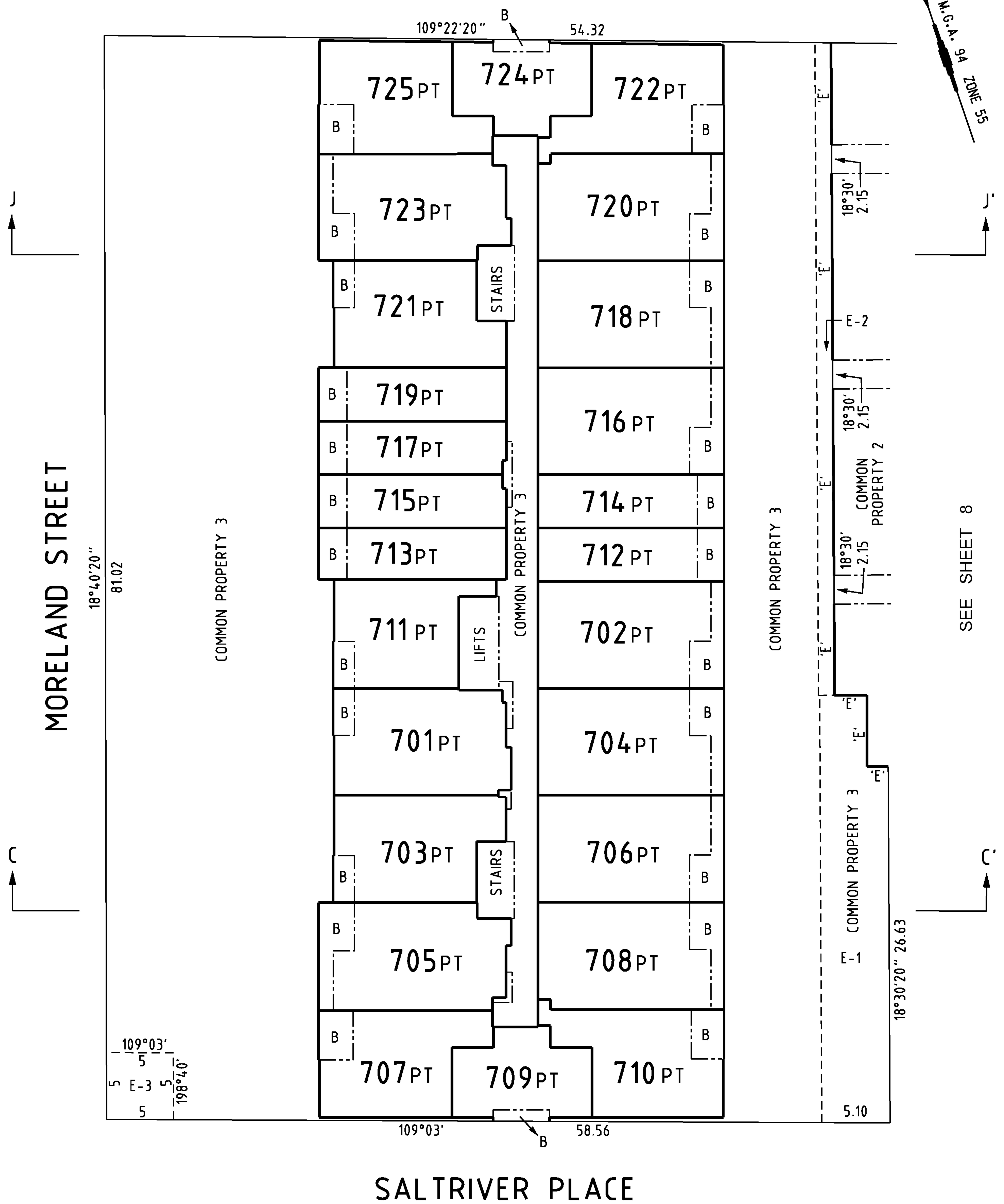

SEE SHEET 8

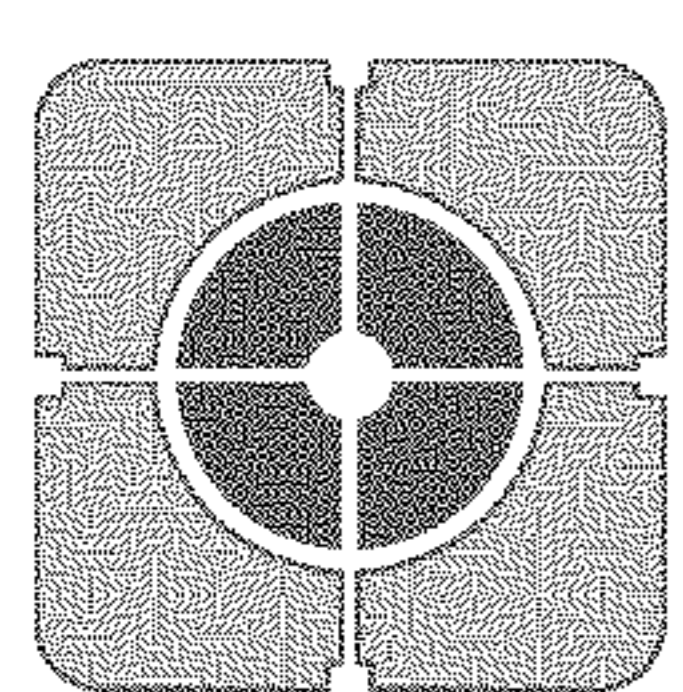

Peninsula Survey Group PTY LTD
 Consulting Land Surveyors
 24A Progress Street, Mornington, VIC. 3931.
 Phone: 9787 2980 mail@peninsulasurvey.com.au
 ACN 067 077 614

FILE REF: 6241 / PS

SCALE
1: 300



ORIGINAL
SHEET SIZE: A3

SHEET 34

Digitally signed by: Alan Leslie Runting (Peninsula Survey Group Pty Ltd),
 Surveyor's Plan Version (4.1),
 15/11/2016 Amended: 16/12/2016

Digitally signed by:
 Maribyrnong City Council,
 16/11/2016,
 SPEAR Ref: S085223M

LEVEL 8-WEST
DIAGRAM 13

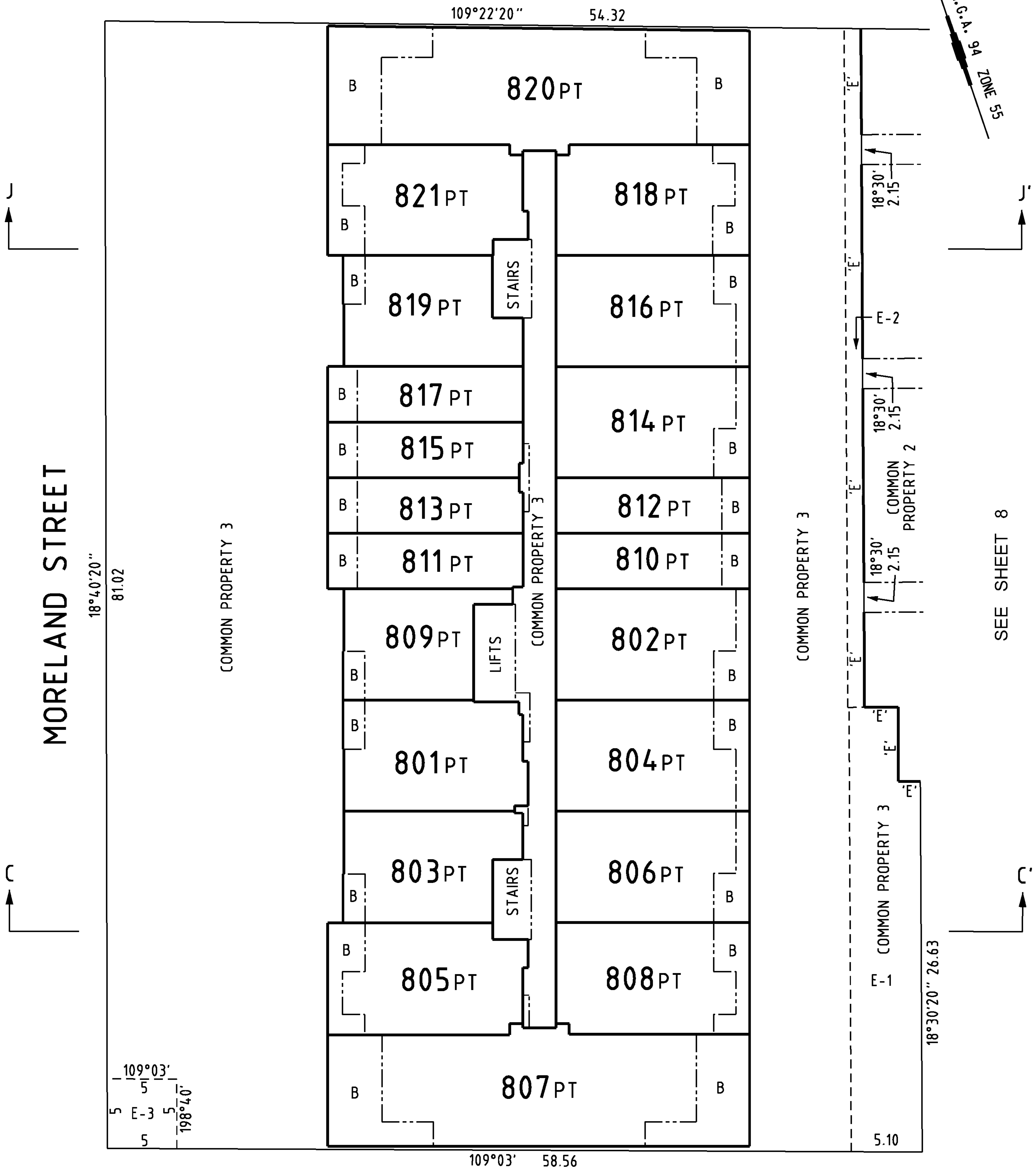
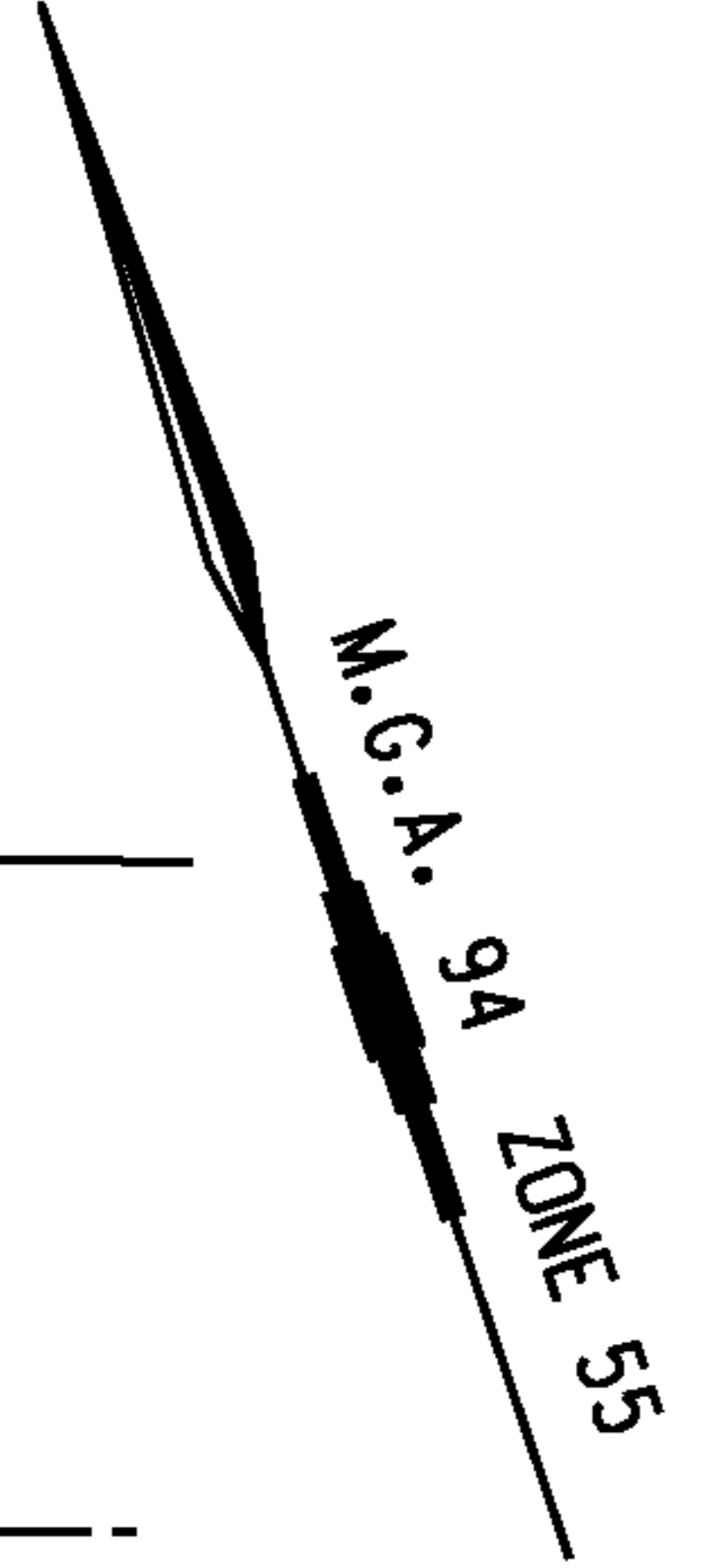

SEE SHEET 8

MORELAND STREET

SALTRIVER PLACE

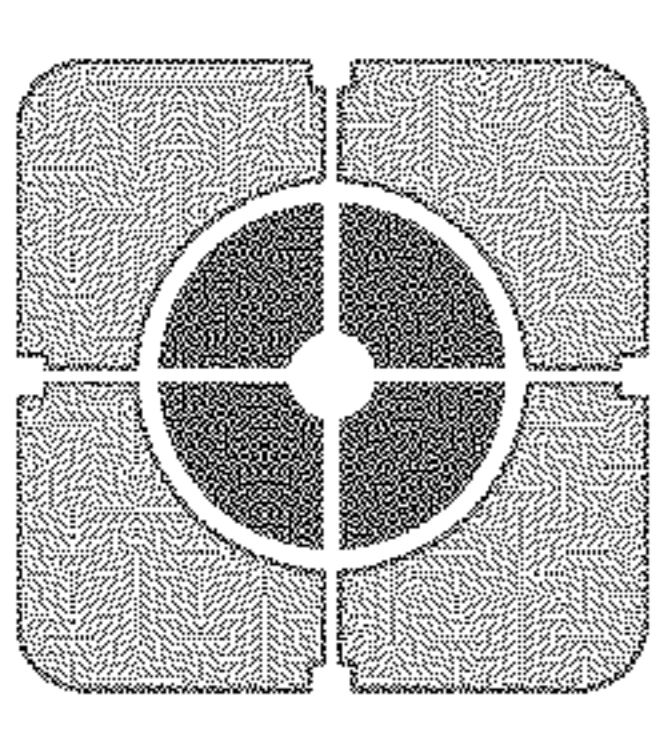

Peninsula Survey Group PTY LTD
 Consulting Land Surveyors
 24A Progress Street, Mornington, VIC. 3931.
 Phone: 9787 2980 mail@peninsulasurvey.com.au
 ACN 067 077 614

FILE REF: 6241 / PS

SCALE
1: 300

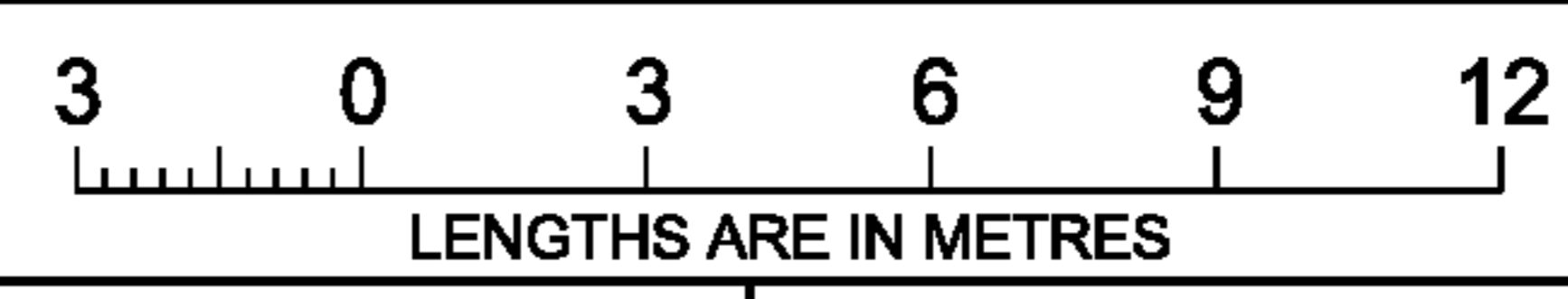

ORIGINAL SHEET SIZE: A3

SHEET 35

Digitally signed by: Alan Leslie Runting (Peninsula Survey Group Pty Ltd),
 Surveyor's Plan Version (4.1),
 15/11/2016 Amended: 16/12/2016

Digitally signed by:
 Maribyrnong City Council,
 16/11/2016,
 SPEAR Ref: S085223M

LEVEL 9-WEST
DIAGRAM 14

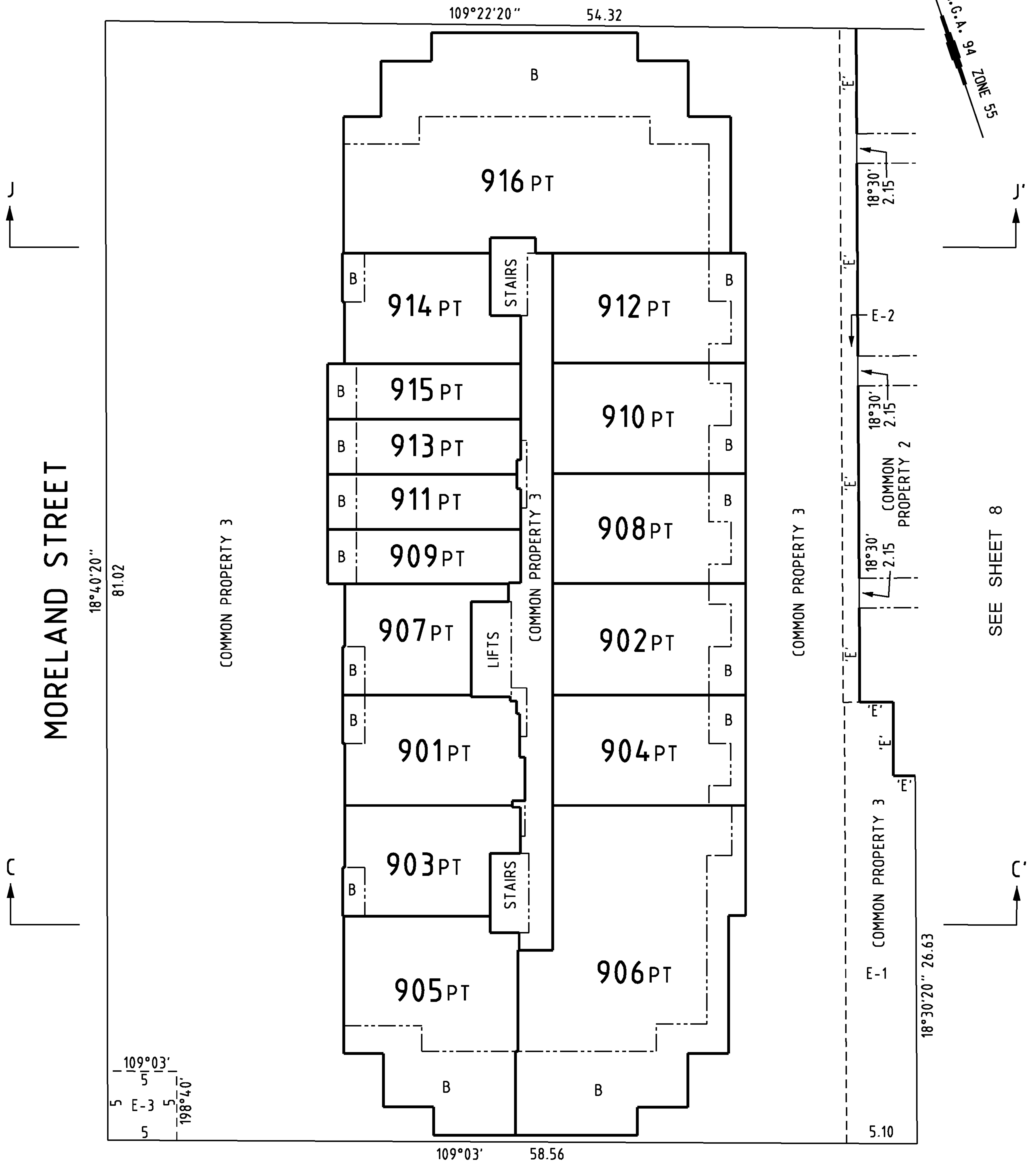

SEE SHEET 8

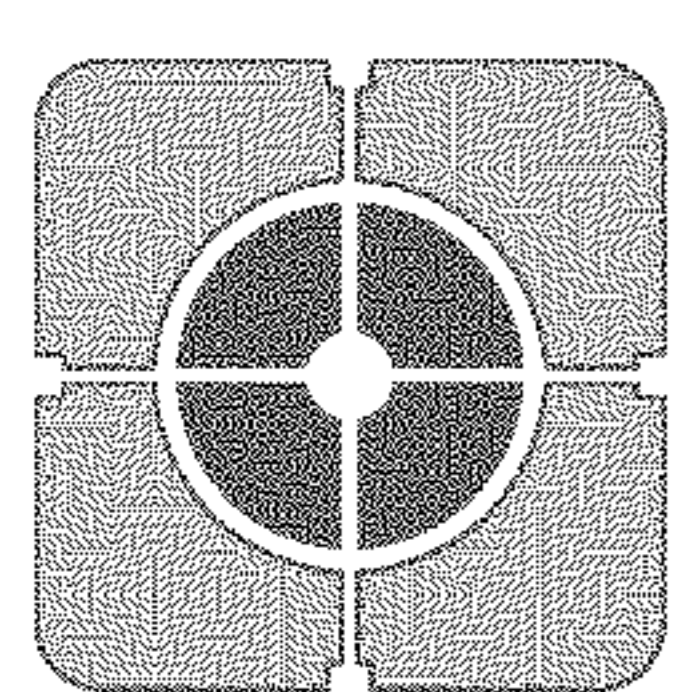

Peninsula Survey Group PTY LTD
 Consulting Land Surveyors
 24A Progress Street, Mornington, VIC. 3931.
 Phone: 9787 2980 mail@peninsulasurvey.com.au
 ACN 067 077 614

FILE REF: 6241 / PS

SCALE
1: 300



ORIGINAL SHEET SIZE: A3

SHEET 36

Digitally signed by: Alan Leslie Runting (Peninsula Survey Group Pty Ltd),
 Surveyor's Plan Version (4.1),
 15/11/2016 Amended: 16/12/2016

Digitally signed by:
 Maribyrnong City Council,
 16/11/2016,
 SPEAR Ref: S085223M

LEVEL 10 - WEST
DIAGRAM 15

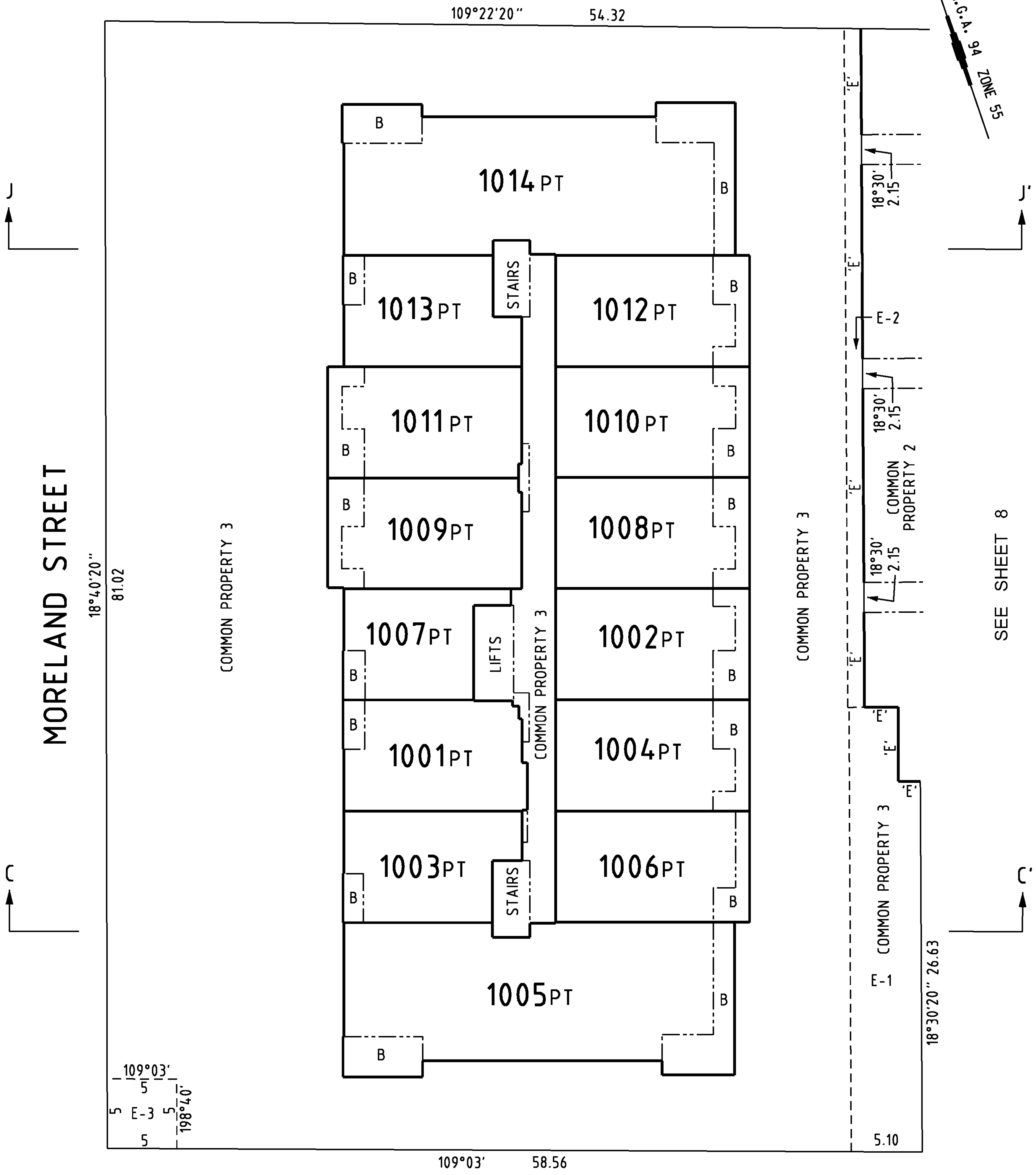
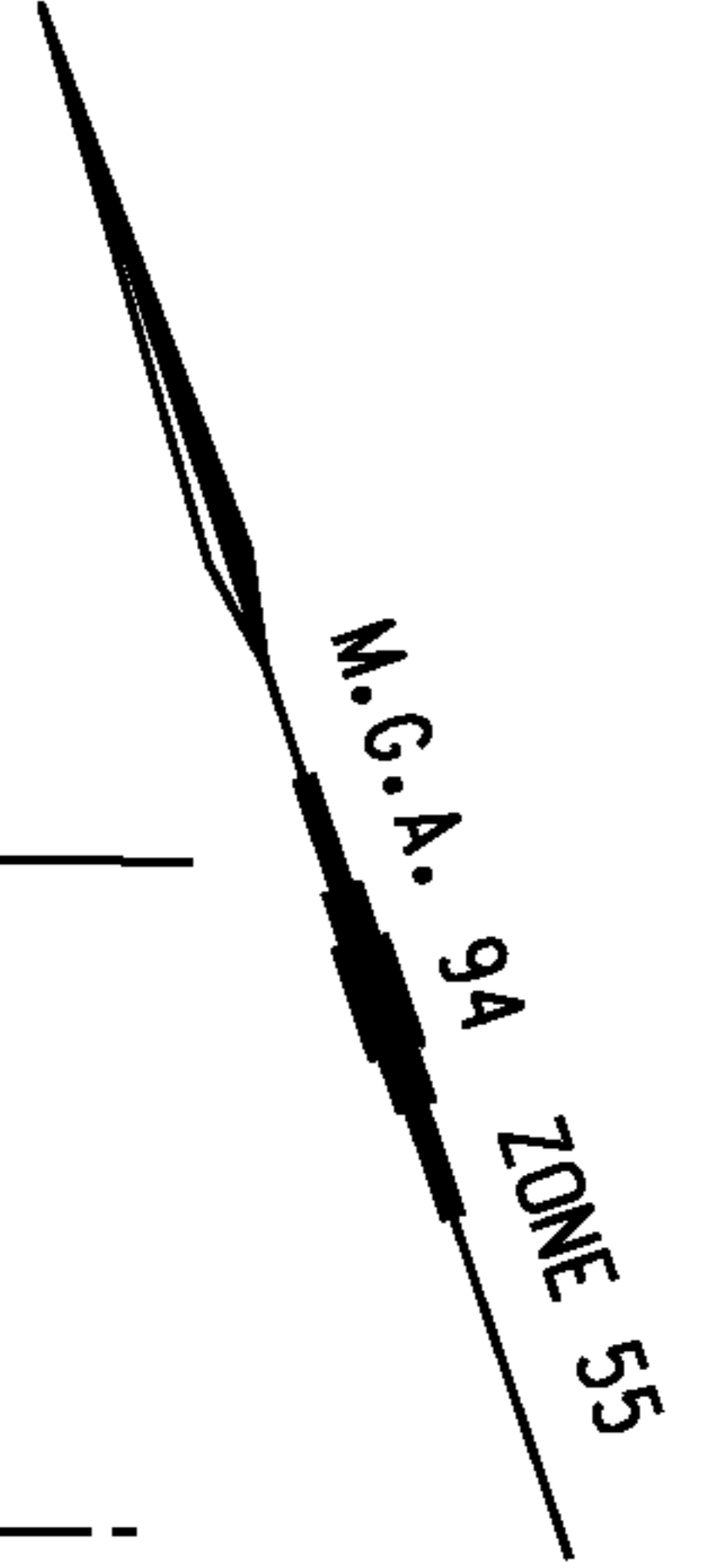

SEE SHEET 8

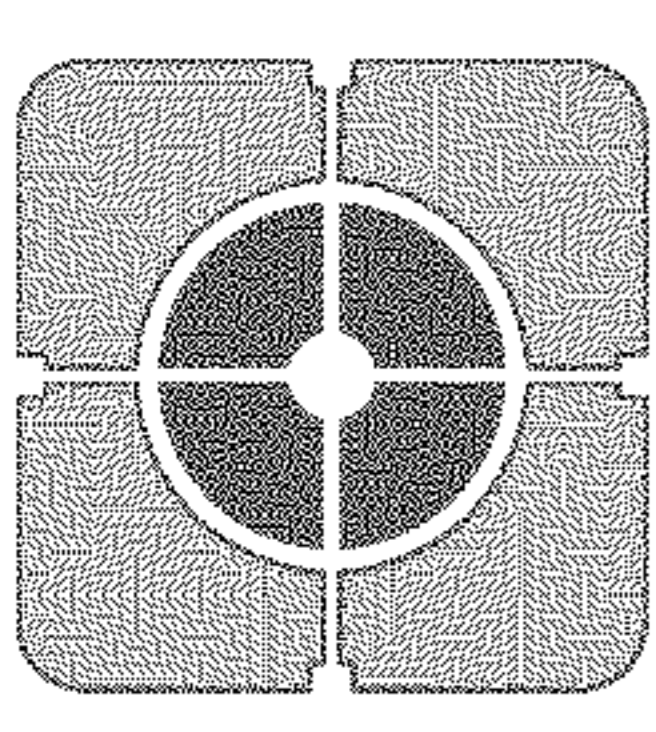

Peninsula Survey Group PTY LTD
 Consulting Land Surveyors
 24A Progress Street, Mornington, VIC. 3931.
 Phone: 9787 2980 mail@peninsulasurvey.com.au
 ACN 067 077 614

FILE REF: 6241 / PS

SCALE
1: 300

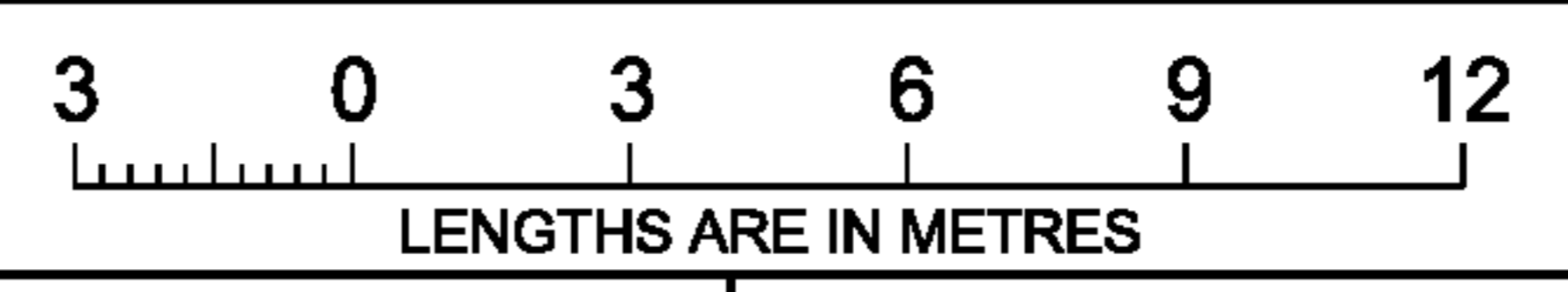

ORIGINAL SHEET SIZE: A3

SHEET 37

Digitally signed by: Alan Leslie Runting (Peninsula Survey Group Pty Ltd),
 Surveyor's Plan Version (4.1),
 15/11/2016 Amended: 16/12/2016

Digitally signed by:
 Maribyrnong City Council,
 16/11/2016,
 SPEAR Ref: S085223M

LEVEL 11-WEST
DIAGRAM 16

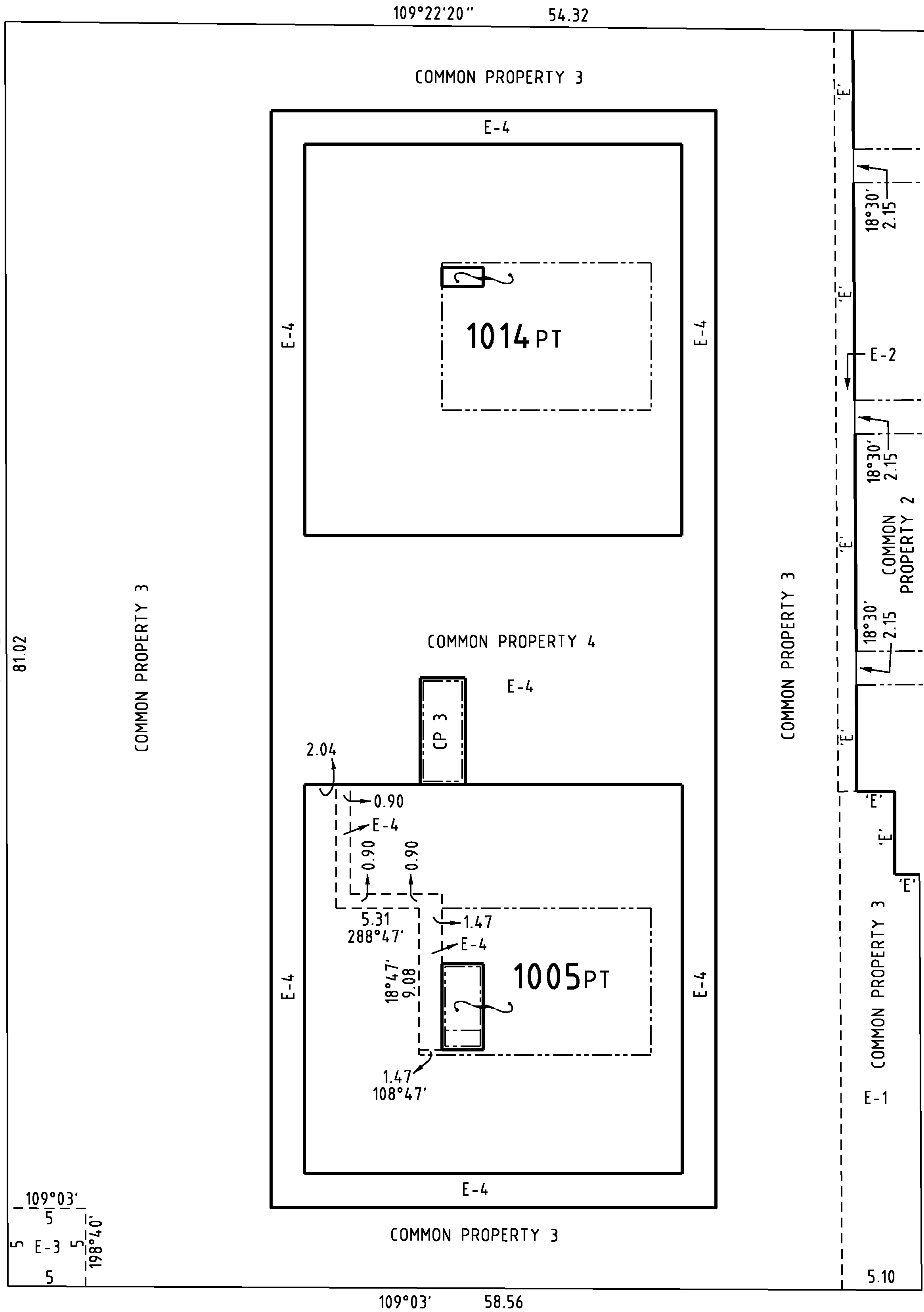
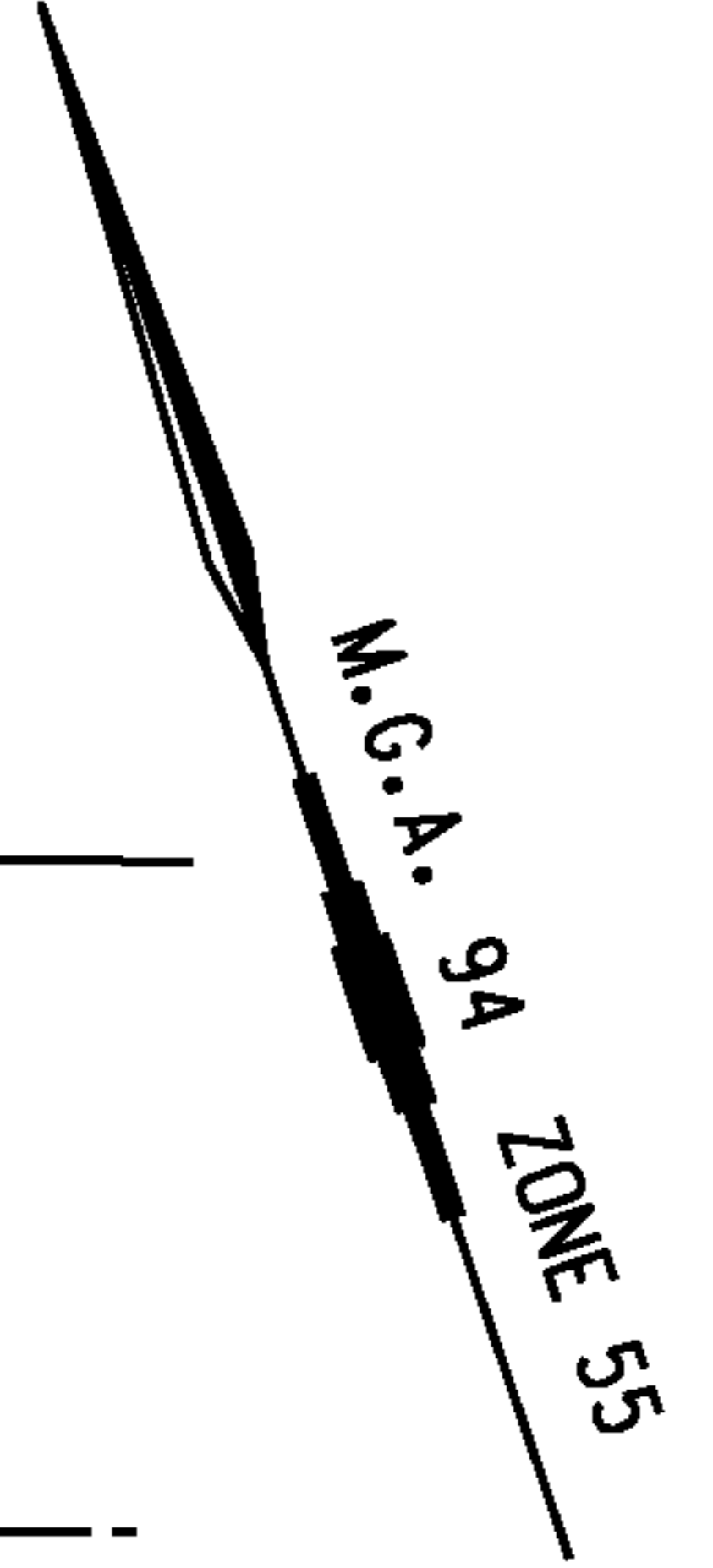

SEE SHEET 8

MORELAND STREET

SALTRIVER PLACE

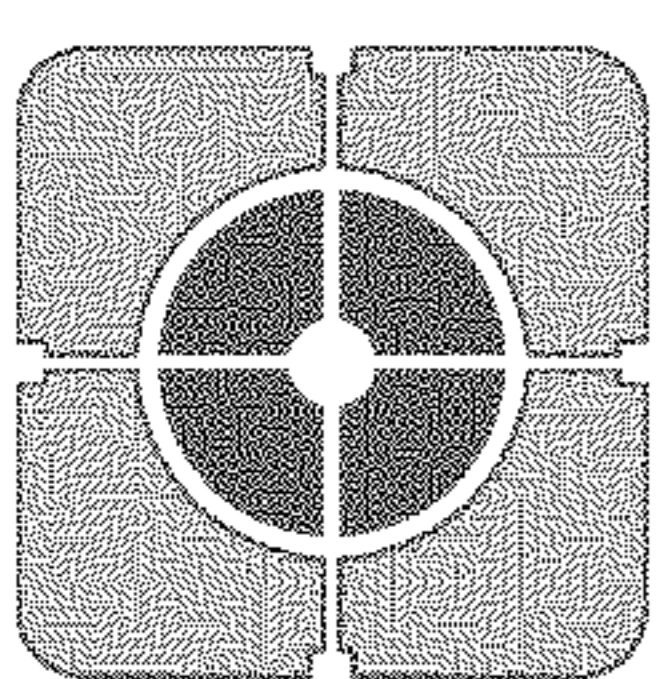

Peninsula Survey Group PTY LTD
Consulting Land Surveyors
24A Progress Street, Mornington, VIC. 3931.
Phone: 9787 2980 mail@peninsulasurvey.com.au
ACN 067 077 614

FILE REF: 6241 / PS

SCALE
1: 300

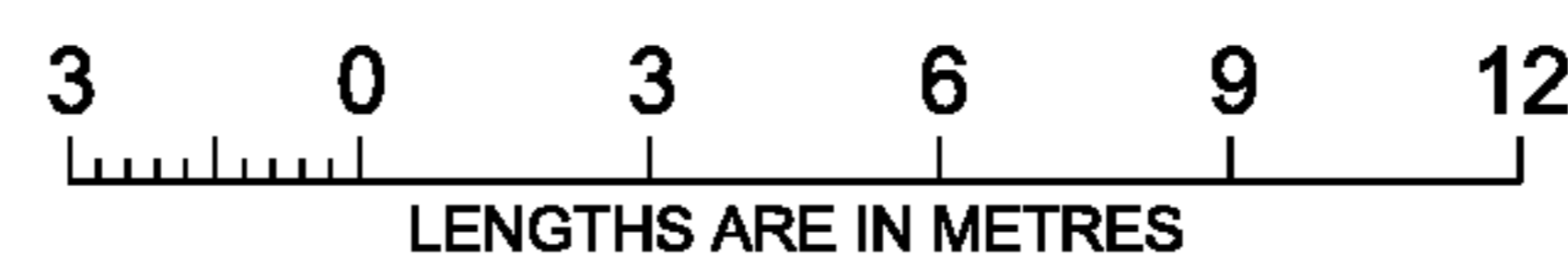

ORIGINAL SHEET SIZE: A3

SHEET 38

Digitally signed by: Alan Leslie Runting (Peninsula Survey Group Pty Ltd),
Surveyor's Plan Version (4.1),
15/11/2016 Amended: 16/12/2016

Digitally signed by:
Maribyrnong City Council,
16/11/2016,
SPEAR Ref: S085223M

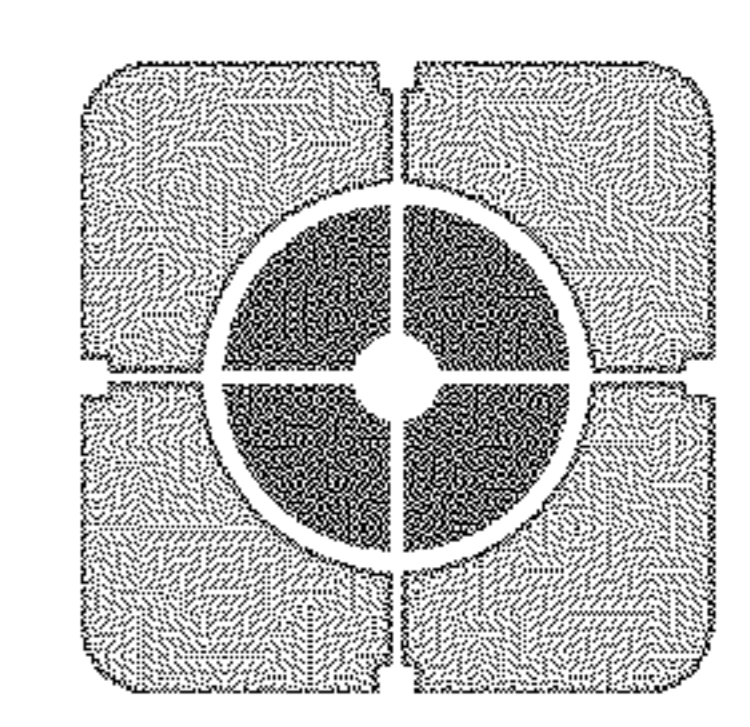



Peninsula Survey Group PTY LTD
 Consulting Land Surveyors
 24A Progress Street, Mornington, VIC. 3931.
 Phone: 9787 2980 mail@peninsulasurvey.com.au
 ACN 067 077 614

FILE REF: 6241 / PS

SCALE N.T.S. 0 LENGTHS ARE IN METRES

Digitally signed by: Alan Leslie Runtling (Peninsula Survey Group Pty Ltd),
 Surveyor's Plan Version (4.1),
 15/11/2016 Amended: 16/12/2016

ORIGINAL SHEET SIZE: A3

Digitally signed by: Maribyrnong City Council,
 16/11/2016,
 SPEAR Ref: S085223M

PS 600696N

C-C CONTINUED - SEE SHEET 13



NOTE: THE LOWER BOUNDARY OF EASEMENT E-4 IS THE TOP SURFACE OF THE LEVEL 11 -WEST FLOOR SLAB. THE UPPER EXTENT OF E-4 IS THE PROJECTION OF THE UPPER SURFACE OF COMMON PROPERTY 3.

* NOTE: PROJECTION OF UNDERSIDE OF FLOOR SLAB

CROSS SECTION C-C'
NOT TO SCALE
(TYPICAL FOR LOTS IN BUILDING 'B')

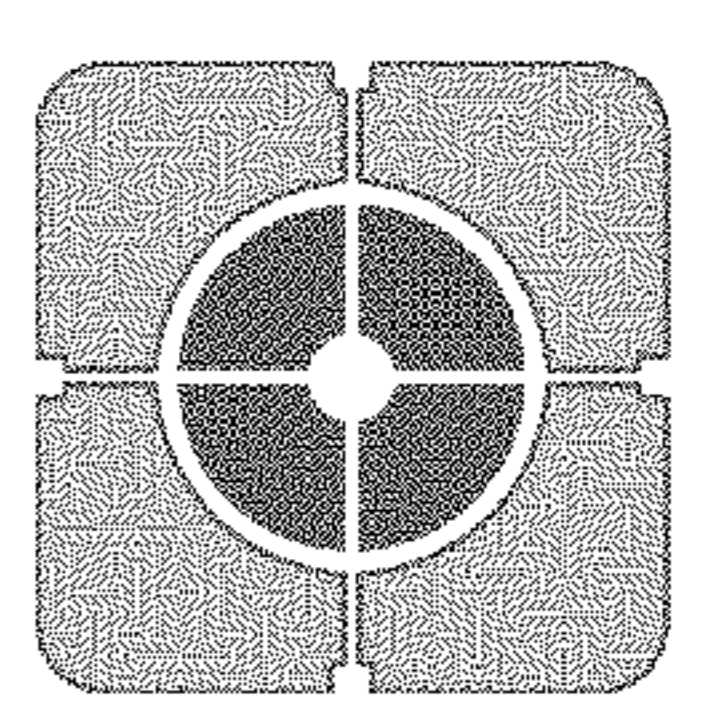
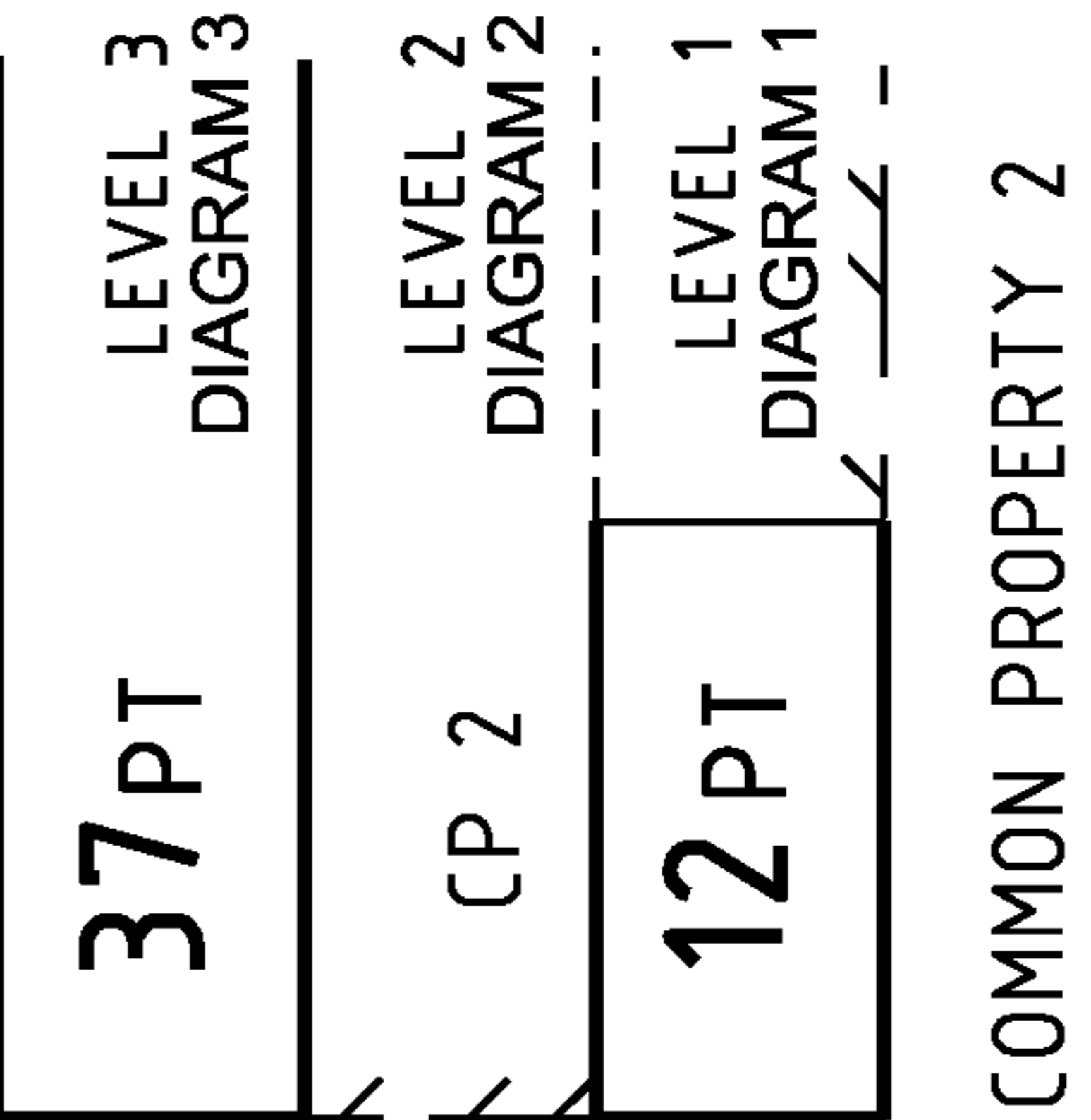

Peninsula Survey Group PTY LTD
Consulting Land Surveyors
24A Progress Street, Mornington, VIC. 3931.
Phone: 9787 2980 mail@peninsulasurvey.com.au
ACN 067 077 614

FILE REF: 6241 / PS

SCALE N.T.S. 0 LENGTHS ARE IN METRES

Digitally signed by: Alan Leslie Runtling (Peninsula Survey Group Pty Ltd), Surveyor's Plan Version (4.1), 15/11/2016 Amended: 16/12/2016

ORIGINAL SHEET SIZE: A3

Digitally signed by: Maribyrnong City Council, 16/11/2016, SPEAR Ref: S085223M

SHEET 40

PS 600696N

NO UPPER BOUNDARY

1014 PT

- LEVEL 11-WEST DIAGRAM 16
- LEVEL 10-WEST DIAGRAM 15
- LEVEL 9-WEST DIAGRAM 14
- LEVEL 8-WEST DIAGRAM 13
- LEVEL 7-WEST DIAGRAM 12
- LEVEL 6-WEST DIAGRAM 11

COMMON PROPERTY 3

COMMON PROPERTY 3

NO UPPER BOUNDARY

COMMON PROPERTY 2

* PROJECTION

* PROJECTION

* NOTE: PROJECTION OF UNDERSIDE OF FLOOR SLAB

CROSS SECTION J - J'
NOT TO SCALE

SALT RIVER PLACE

COMMON PROPERTY 3

COMMON PROPERTY 3

| | | | | | | | | | | | | |
|-----|-----|-----|-----|-----|-----|-----|-----|-----|-----|-----|-----|-----|
| 211 | 913 | 911 | 311 | 313 | 315 | 317 | 319 | 915 | 615 | 517 | 519 | 909 |
| PT | PT | PT | PT | PT | PT | PT | PT | PT | PT | PT | PT | PT |

| | | | | | | | | | | |
|-----|-----|-----|-----|-----|-----|-----|-----|-----|-----|-----|
| 613 | 617 | 619 | 713 | 715 | 717 | 719 | 811 | 813 | 815 | 817 |
| PT | PT | PT | PT | PT | PT | PT | PT | PT | PT | PT |

CROSS SECTION K - K'
NOT TO SCALE

SALT RIVER PLACE

COMMON PROPERTY 3

COMMON PROPERTY 3

| | | | | | | | | | | | | | | |
|-----|-----|-----|-----|-----|-----|-----|-----|-----|-----|-----|-----|-----|-----|-----|
| 409 | 111 | 109 | 411 | 511 | 107 | 105 | 809 | 711 | 611 | 907 | 103 | 101 | 515 | 524 |
| PT | PT | PT | PT | PT | PT | PT | PT | PT | PT | PT | PT | PT | PT | PT |

| | | | | | | | | | |
|-----|----|-----|-----|-----|-----|-----|-----|-----|-----|
| 321 | 81 | 115 | 121 | 309 | 209 | 424 | 119 | 324 | 325 |
| PT | PT | PT | PT | PT | PT | PT | PT | PT | PT |

| | | | | | | | | | | | | | | | | | | | | | | | | | | | | |
|----|-----|-----|-----|-----|-----|-----|-----|-----|-----|-----|-----|-----|-----|-----|-----|------|-----|-----|------|-----|-----|------|------|------|-----|-----|-----|----|
| 81 | 604 | 606 | 608 | 616 | 618 | 620 | 905 | 217 | 906 | 916 | 219 | 419 | 602 | 113 | 807 | 1014 | 215 | 415 | 1005 | 213 | 413 | 1006 | 1010 | 1004 | 104 | 417 | 820 | |
| PT | PT | PT | PT | PT | PT | PT | PT | PT | PT | PT | PT | PT | PT | PT | PT | PT | PT | PT | PT | PT | PT | PT | PT | PT | PT | PT | PT | PT |

| | | | | | |
|-----|-----|-----|-----|-----|-----|
| 508 | 516 | 518 | 520 | 523 | 218 |
| PT | PT | PT | PT | PT | PT |

COMMON PROPERTY 3

COMMON PROPERTY 3

CROSS SECTION L - L'
NOT TO SCALE

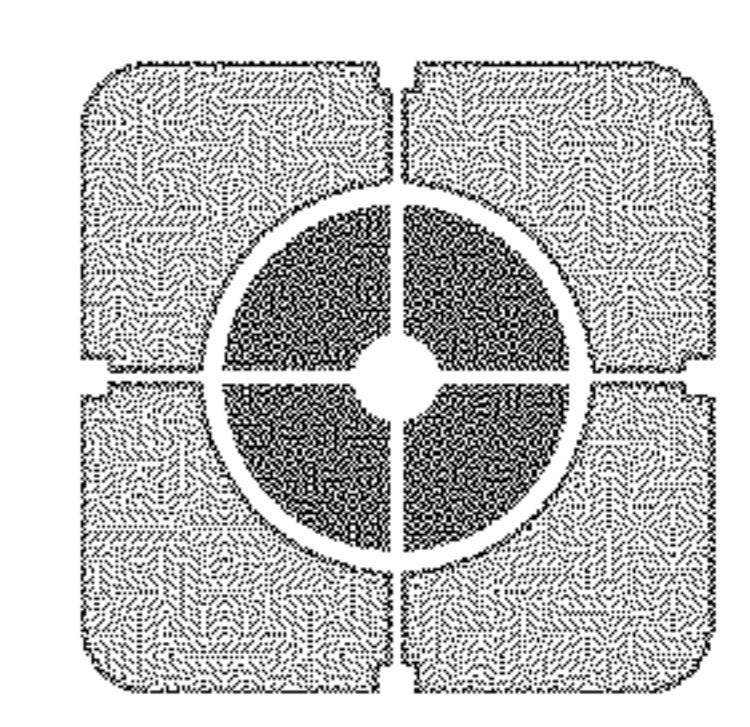

Peninsula Survey Group PTY LTD
Consulting Land Surveyors
 24A Progress Street, Mornington, VIC. 3931.
 Phone: 9787 2980 mail@peninsulasurvey.com.au
 ACN 067 077 614

FILE REF: 6241 / PS

SCALE N.T.S.
 0 LENGTHS ARE IN METRES

Digitally signed by: Alan Leslie Runtling (Peninsula Survey Group Pty Ltd),
 Surveyor's Plan Version (4.1),
 15/11/2016 Amended: 16/12/2016

Digitally signed by:
 Maribyrnong City Council,
 16/11/2016,
 SPEAR Ref: S085223M

ORIGINAL SHEET SIZE: A3

SHEET 41

